S U P P L Y I N G C L E A N A I R T O I N D U S T R Y

OWNERS MANUAL
MODEL M66V
Media Air Cleaner



The M66 is a self-contained media air cleaning system designed for use in source capture applications where mobility is desired. The M66 can be ordered in a three-stage filtration which will effectively remove a broad range of airborne contaminants including fine dust, smoke, soot, vapors, mist, VOC's and more at a rate of up to 2700 cfm.



For further information:

BERRIMAN ASSOCIATES
1-800-480-3630
www.berriman.com

TABLE OF CONTENTS

	PAGE
PRINCIPLES OF OPERATION	2
DIMENSIONS	3
SPECIFICATIONS	4
PLANNING THE INSTALLATION	4
ASSEMBLY	5
CHECKOUT AND OPERATION	6
ADJUSTMENTS	7
MAINTENANCE	7
ELECTRICAL SCHEMATICS	8
PARTS LIST	10
EXPLODED VIEW OF M33V AIR CLEANER	11
WARRANTY	12

HOW AIRBORNE CONTAMINATION IS REMOVED

Dirty air passes through the prefilter. Large particulate, such as lint, is removed by the prefilter. The remaining smaller particulate is then captured by the primary filter. As the contaminant load on the filters increases, the filters become more efficient in capturing the

smaller particles. At the same time, however, the dirty filter allows less air to pass through resulting in less particle collection and a decrease in the overall effectiveness of the air cleaner.

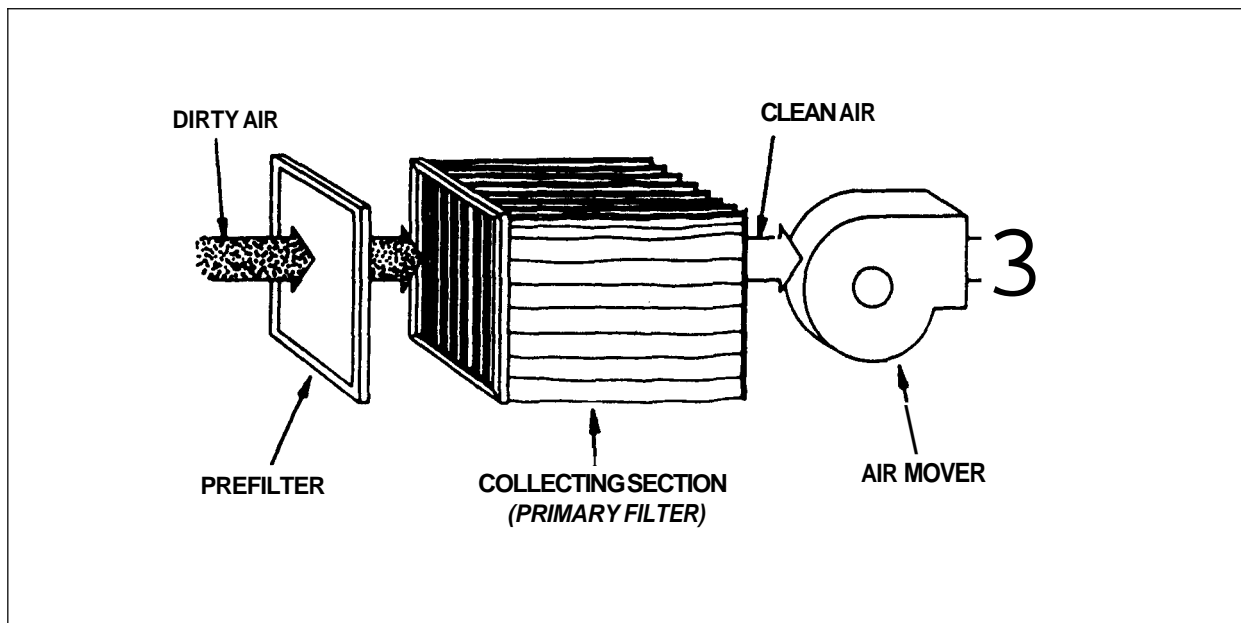

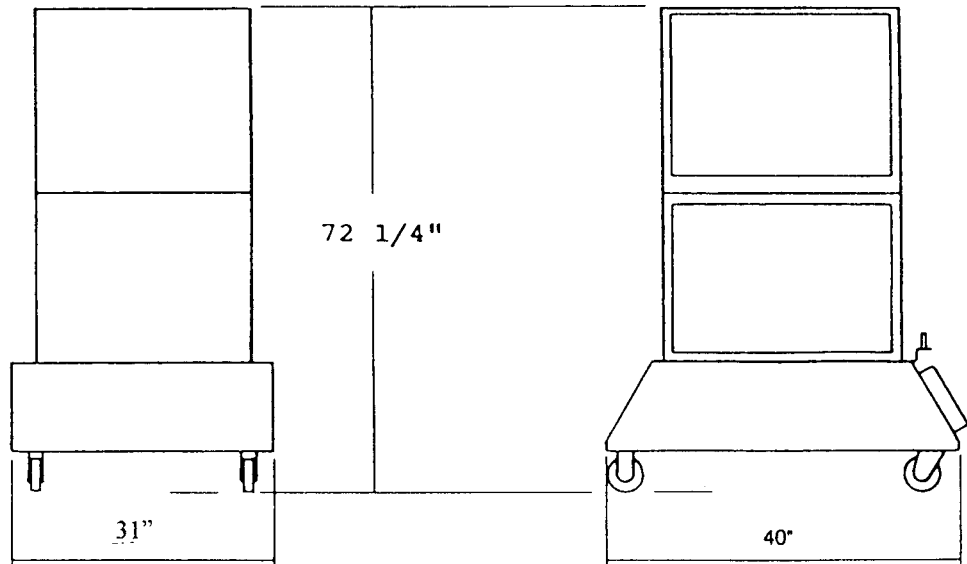
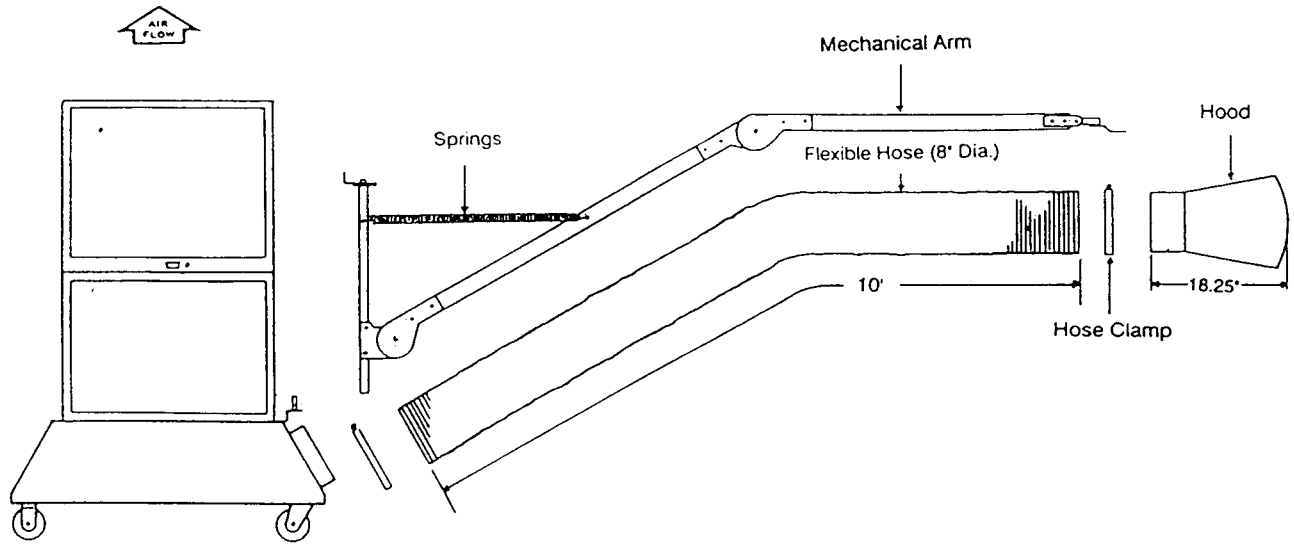

METRIC CONVERSION	FORMULA
Ins. to mm	Ins. x 25.4
Lbs. to kgs.	Lbs. x .455
Ins. w.g. to kPa	Ins. w.g. x .2488
CFM to m ³ /h	CFM x 1.6992
Ft ² to m ²	Ft ² x .0929

FIGURE 1 - M66V DIMENSIONS

SPECIFICATIONS

IMPORTANT

THE SPECIFICATIONS GIVEN IN THIS PUBLICATION DO NOT INCLUDE NORMAL MANUFACTURING TOLERANCES. THEREFORE, THIS UNIT MAY NOT MATCH THE LISTED SPECIFICATIONS EXACTLY. ALSO, THIS PRODUCT IS TESTED AND CALIBRATED UNDER CLOSELY CONTROLLED CONDITIONS, AND SOME MINOR DIFFERENCES IN PERFORMANCE CAN BE EXPECTED IF THOSE CONDITIONS ARE CHANGED.

Specifications:

Dimensions: 73" H x 20" W x 40" L

Weight: 368 lbs. installed weight
440 lbs. shipping weight
Optional carbon module adds 60 lbs. to the installed and shipping weight.

Cabinet: 16 gauge welded steel cabinet with a baked enamel, textured coated finish. Built-in sump and drain connection for oil mist removal. Four heavy-duty swivel locking casters.

Voltage	Phase	1 Hp		2 Hp		3 Hp	
		Amps	Amps	Amps	Amps	Amps	Amps
110-120	1	12	NA	NA	NA	NA	NA
204-240	1	6.6	9	NA	NA	NA	NA
208-240	3	3.8	7	7	9	9	9
440-480	3	1.9	3.5	3.5	4.4	4.4	4.4

Motor: 1 Hp sealed ball bearings and thermally protected. Adjustable motor sheave allows for field adjustments to the rated airflow.

Blower: Forward curved, ball bearing, belt driven, centrifugal blower. This blower is capable of moving 4400 cfm free air.

Instrumentation: **Dirty Filter Gauge** - Factory-installed pressure gauge designed to determine filter replacement cycle.

Indicator Light - Light indicates that the blower motor is energized properly.

Mechanical Arm: Ten-foot externally supported arm swings 180° on its axis and reaches from floor to

11' high. Once this arm is positioned, the hood and hose remain in place until moved.

Hose: Eight-inch diameter EPDM rubber hose with an *encased* wire helix. This hose is 10' long.

Prefilter: 90-95% efficiency, pleated, 24" x 24" x 4".

Airflow Efficiency:

Stock No.	Filter	(CFM=Cubic Feet Per Minute Per Arm)					
		1 Hp		2 Hp		3 Hp	
		1 Arm	2 Arm	1 Arm	2 Arm	1 Arm	2 Arm
41072	95% Bag	1155	865	1575	1050	1665	1245
41056	85% Bag	1170	870	1595	1065	1675	1260
41055	65% Bag	1175	915	1600	1115	1700	1320
41057	50% Bag	1190	955	1620	1170	1725	1375

*Efficiency based on ASHRAE Dust Spot 52-76.

Carbon Filter Option - PN 07096: Forty-four lbs. activated, refillable carbon module. If the carbon filter module is to be used as the third stage of filtration behind the prefilter and primary filter, then the optional extended service filter will be substituted for the standard bag to allow room for the carbon filter. Please note that the maximum airflow rating for the carbon module is 1000 cfm. If the carbon filter is ordered, the air flow will be factory-set at 1000 cfm.

Noise Levels:

Distance in Feet	1 HP
9 Feet	67 dBA
15 Feet	66 dBA

Manufacturer has a policy of continuing product improvement and reserves the right to make changes in design and specifications without notice.

PLANNING THE INSTALLATION

WARNING

The M66V Industrial Roll-around Media Air Cleaner is not explosion-proof. It must not be located or used where there is any danger of gas, vapor, or dust explosion.

INTRODUCTION

Clean air is the subject of numerous laws and regulations. Typical requirements in the United States are those put out by the Occupational Safety and Health Administration (OSHA). Private groups, such as the American Society of Heating, Refrigeration and Air Conditioning Engineers (ASHRAE), have also published

numerous recommendations.

Normally, clean air is defined in regulations and recommendations as air having a limited amount of contaminant in it, commonly expressed as parts per million, or milligrams per Cubic meter. Approved counteractions are intended to lower or eliminate the amount of contaminants in the air. One of the more common methods of achieving this goal is through the use of media air cleaners.

At no time should a media air cleaner be placed where there is a potential for explosion due to the presence of explosive dusts, gases, or vapors. Contact the nearest SmokeMaster representative for assistance in determining the correct application of a media air cleaner.

SIZING

Sizing is the process of determining the amount of air cleaning necessary in any given application. Since the M66V is a source capture air cleaner, the sizing process is relatively simple—provide one source capture hood per contaminant source.

LOCATION

For most efficient operation, the M66V source capture

hood should be placed as close to the contaminant source as possible. The maximum distance between the contaminant producer and the source capture hood should not exceed 18 inches. Therefore, in locating the M66V, be sure that the mechanical arm is capable of extending the source capture hood to within 18 inches of the contaminant source.

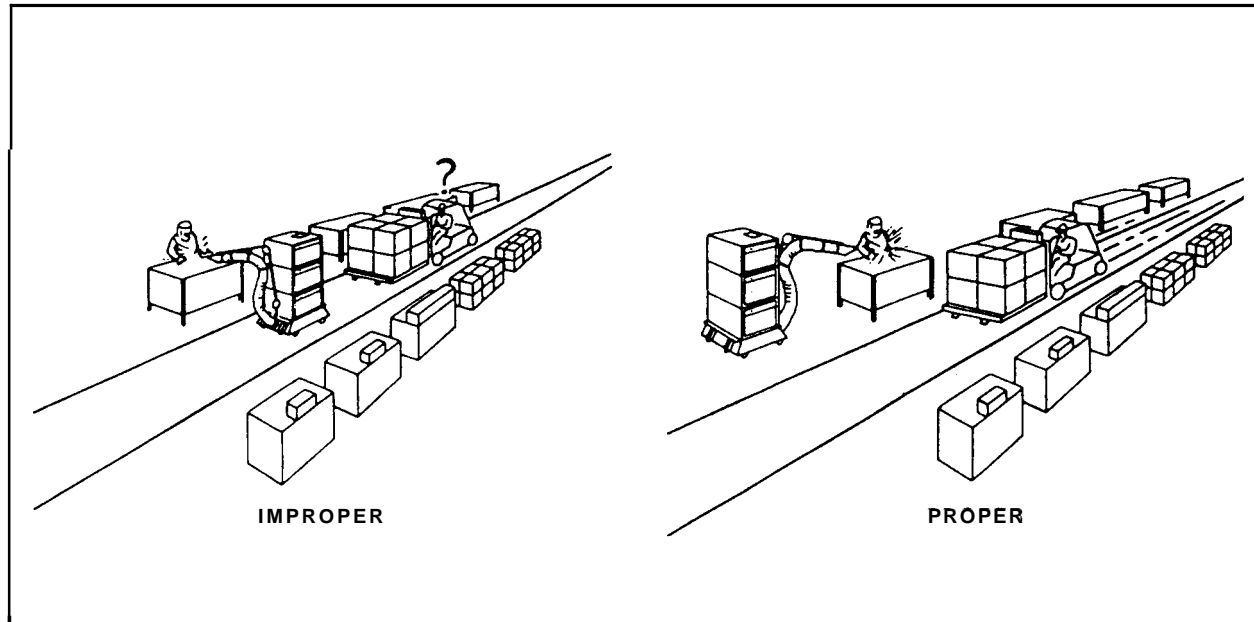

FIGURE 2 * EXAMPLES OF PROPER AND IMPROPER M66V LOCATIONS

ASSEMBLY

WHEN ASSEMBLING THIS PRODUCT

1. Read these instructions carefully. Failure to follow them could damage the product or cause a hazardous condition.
2. Check the electrical ratings given on the air cleaner schematic to the power source to insure compatibility.
3. After assembly is complete, check out the product operation as provided in these instructions.

CAUTION

1. Do NOT connect the power source until the air cleaner is completely assembled.
2. If the air cleaner must be turned on for an electrical check, be extremely careful in avoiding electrical shock. Also, take care to avoid the air cleaner's moving parts.

UNPACKING

The M66V is shipped completely assembled except for the mechanical arm. The mechanical arm assembly is packaged in a separate box. Remove all shipping cardboard and banding. Be sure to inspect the packaging material before discarding it.

ASSEMBLING THE M66V

Tools needed:

1. Standard screwdriver
2. Phillips screwdriver
3. 7/16" wrench

NOTE: See Figure 1, Page 3, when assembling the M66V.

Step 1

Remove the two Phillips screws and lock washers from the side of the M66V. ~~Set~~ the support tube on the arm assembly onto the 7/8" pin on the cart. Fasten the support bracket of the arm to the M66V cabinet using the two Phillips 1/4-20 screws and lock washers.

Step 2

Mount the hood to the end swivel bracket of the arm using the ~~two~~ 1/4-20 hex head bolts and 1/4-20 nuts.

Step 3

Attach the two counterbalance springs from the studs on the 1" x 2" aluminum tube to the studs on the one-inch square support tube.

Step 4

Slip the hose and clamp over the opening flange on the roll-around cart. Slip the end of the hose and second clamp over the hood flange three to four inches and tighten the clamp.

Step 5

Tie the hose to the mechanical arm using the two nylon belts provided.

WIRING

The M66V has no special wiring requirements. It comes equipped with a 10-foot power cord and plug. The power source must be compatible with the voltage and frequency of the M66V. The rating on the M66V is located on the schematic on the inside of the filter access door. Route the power cord so that it is out of the way of the building's occupants. Do not use an extension cord.

CHECKOUT AND OPERATION

CHECKOUT

Before operating the M66V, check out the installation using the following procedures:

1. Make sure the air cleaner is oriented for good air circulation where it will not interfere with personnel and material traffic. Keep out of fire lanes and away from overhead cranes.
2. Check that the tension on the arm joints is correct so that the arm maintains a proper position. If not, readjust the tension adjustment screws (two adjustment screws).
3. Be sure that the source capture hood can be placed within 18 inches of the contamination.
4. Make sure that the prefilter and the primary filter are properly oriented and the airflow arrows are pointing toward the blower.
5. Make sure the filter change gauge (manometer) is level. ~~See~~ the spirit level in the right hand corner of the gauge.
6. Check the oil level in the filter change gauge, and adjust the zero knob so the oil level is at zero inches of water when the M66V is turned off.

OPERATION

1. Turn on the air cleaner control switch. Make sure the blower is providing a strong discharge. Please note that the M66V air flow was factory-set at the maximum, considering the filter efficiency and other options ordered, such as impingers and plenums.

If decreased air flow is desired, it can be accomplished by adjusting the variable sheave on the motor. It is very important to measure the amperage before and after the adjustments are made on the variable motor

sheave to insure that the motor is not overloaded. The rated amperage is listed on the schematic on the filter access door. To adjust the motor sheave, see Adjustments on Page 7.

2. The indicator light should be on whenever the blower is on.
3. The filter gauge should be level and should read zero when the M66V is turned off. If it does not read zero, adjust the reading with the adjustment knob on the gauge.

CALIBRATION OF THE DIRTY FILTER GAUGE

After the air cleaner has been installed and is ready for operation, the air filter gauge must be calibrated. ~~See~~ the following simple steps:

Step 1

Check that the filter gauge is level. ~~See~~ the spirit level in the right hand corner of the gauge.

Step 2

Check the red oil level, and adjust the zero knob so that the oil level is at zero inches of water when the air cleaner is turned off.

Step 3

Turn the air cleaner on with the clean filters in place. Place the green arrow adjacent to the point at which the red oil rises. The green arrow will indicate clean filters.

Step 4

Place the red arrow on the gauge scale one inch higher (according to the scale) than the green arrow. This will indicate dirty filters. A one-inch rise in static pressure indicates a reduction in air flow of approximately twenty-five percent.

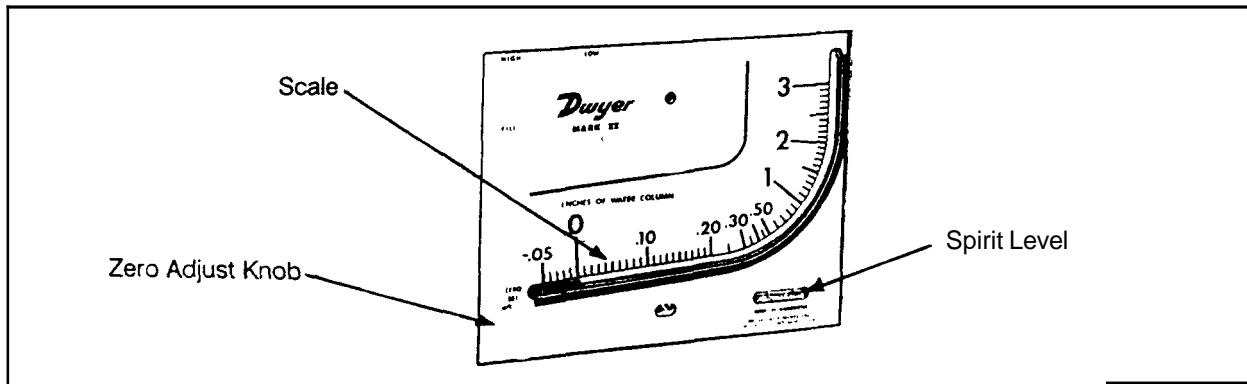

FIGURE 3 - DIRTY FILTER GAUGE

ADJUSTMENTS

AIR FLOW VOLUME (CFM)

The air flow for the **M66V** is factory-set at the maximum volume of air. If reduced air flow is desired, it can be accomplished by adjusting the variable motor sheave.

TO ADJUST THE BLOWER CAPACITY:

1. Turn the air cleaner off, and open the access door to the blower and motor section of the air cleaner.
2. Loosen the two bolts locking the end of the motor rail in position. Remove the belt.
3. Loosen the Allen setscrew on the face of the motor sheave.
4. Rotate the sheave into a position which gives the desired blower capacity.
5. Measure the amperage after the sheave adjustment to insure that you do not exceed the rated amperage.

NOTE: When the sheave is rotated all the way into the shaft, the blower capacity is at its maximum. When the sheave is rotated five turns out on the shaft, the blower capacity is at its minimum. **DO NOT ROTATE THE ADJUSTABLE SHEAVE MORE THAN FIVE TURNS OUT ON THE SHAFT.** The sheave may already be adjusted one or more turns out on the shaft.

CAUTION

Adjusting the variable sheave changes the load on the motor. Do not exceed the rated amperage for the motor.

MAINTENANCE

CAUTION

Always disconnect the power to the **M66V** before working on or near the air cleaner.

FILTER MAINTENANCE/REPLACEMENT

Dirty air passes through the prefilter. Large particulate, such as lint, is removed by the prefilter. The remaining particulate is then captured by the primary filter.

As the contaminant load on the filters increases, the filters become more efficient in capturing the smaller particles. At the same time, however, the dirty filter

allows more air to pass through, resulting in less particle collection and a decrease in the overall efficiency of the air cleaner.

The **M66V** Air Cleaner is equipped with a pressure gauge which indicates the restriction to air flow caused by the filters loading with particulate. When the air filter gauge reaches the red arrow or a noticeable reduction in air flow occurs, it is time to clean or replace the prefilter and possibly the primary filter.

Step 1

Turn off the air cleaner. Open up the filter access doors, and slide out the prefilter.

Step 2

If the particulate is dry, the standard four-inch pleated prefilter can be cleaned by shaking or vacuuming. If the prefilter does not come clean after vacuuming or is saturated with oil, the prefilter should be replaced.

Step 3

Replace the prefilter, and turn on the air cleaner. The reading on the air filter gauge should be at or near the green arrow. If no performance improvement is evident after cleaning or replacing the prefilter, the primary filter will have to be replaced. In most cases, the prefilter can be replaced several times before the primary filter will need to be replaced.

NOTE: An increase of one inch on the gauge would be approximately a 25% decrease in air flow. If the reduction in air flow is not a problem, the air cleaner can be operated beyond this point. The red arrow can be moved to the point at which the decrease in air flow becomes a problem.

GAUGE MAINTENANCE

Check the oil level occasionally, and adjust the zero knob as required. Be sure all pressure is removed by turning the air cleaner off before adjusting the zero knob. If it becomes necessary to add more oil to the gauge, be certain to use only Dwyer Red Oil which is provided with the air cleaner. Other fluids may damage the gauge. To fill the gauge, back out the zero adjust knob until it stops, then turn in approximately three full turns so there is room for adjustment in either direction.

Clean the gauge with a soft cloth using a little pure soap and water. Use of a small brush will aid in cleaning the knobs. Avoid cleaning fluids and liquid

soaps which may have chlorinated solvents in them, as they may damage the gauge.

CARBON MODULE MAINTENANCE (OPTIONAL)
The M66V can be ordered with an optional carbon module. This module is refillable.

WARNING

It is the customer's responsibility to determine the suitability of the carbon filter for any particular application or purpose. The effectiveness of activated carbon must be routinely monitored. In addition, certain substances can combine in the carbon which can result in a fire hazard. Manufacturer accepts no liability for the activated carbon effectiveness or fire hazard.

1. Open the filter access door.
2. Slide the used carbon module out of the filter track which is behind the primary filter track. Caution - the carbon module weighs approximately 60 lbs. Use appropriate means to support the carbon module during service.
3. Refill the carbon module by removing the cover held on by four screws and pouring out the used carbon in an appropriate container. This used carbon must be reactivated or disposed of in the proper manner. Pour in the new or reactivated carbon, and replace the cover and four screws.
4. Slide the module back into the filter track, and close the filter access door.

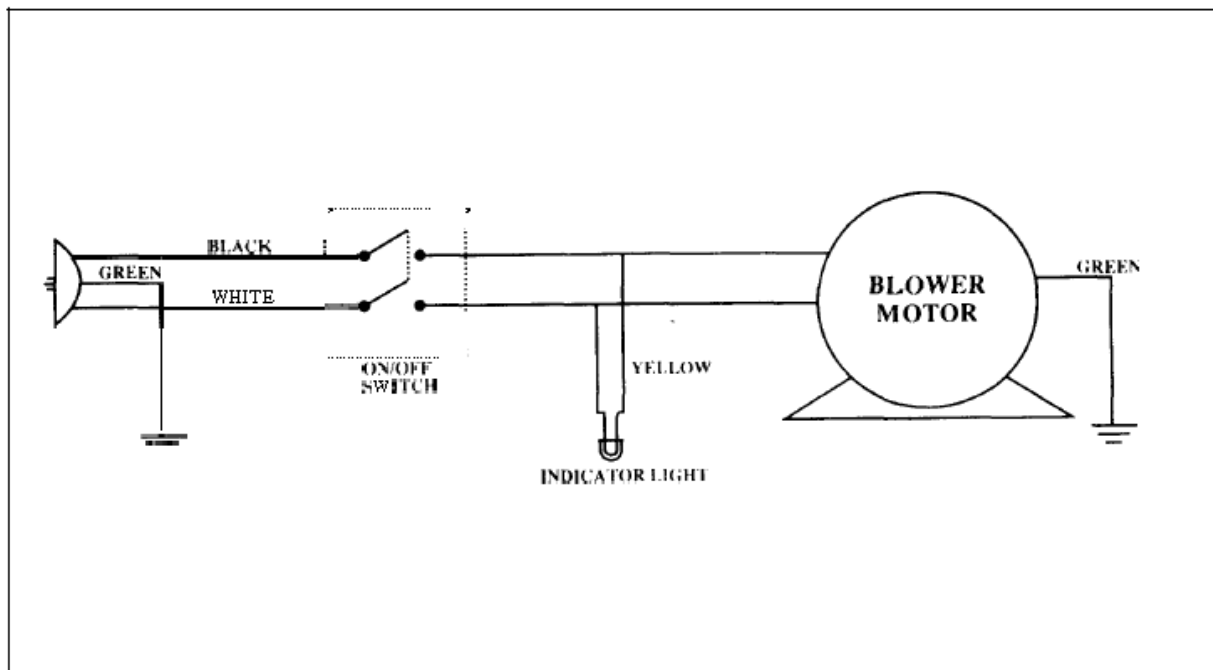
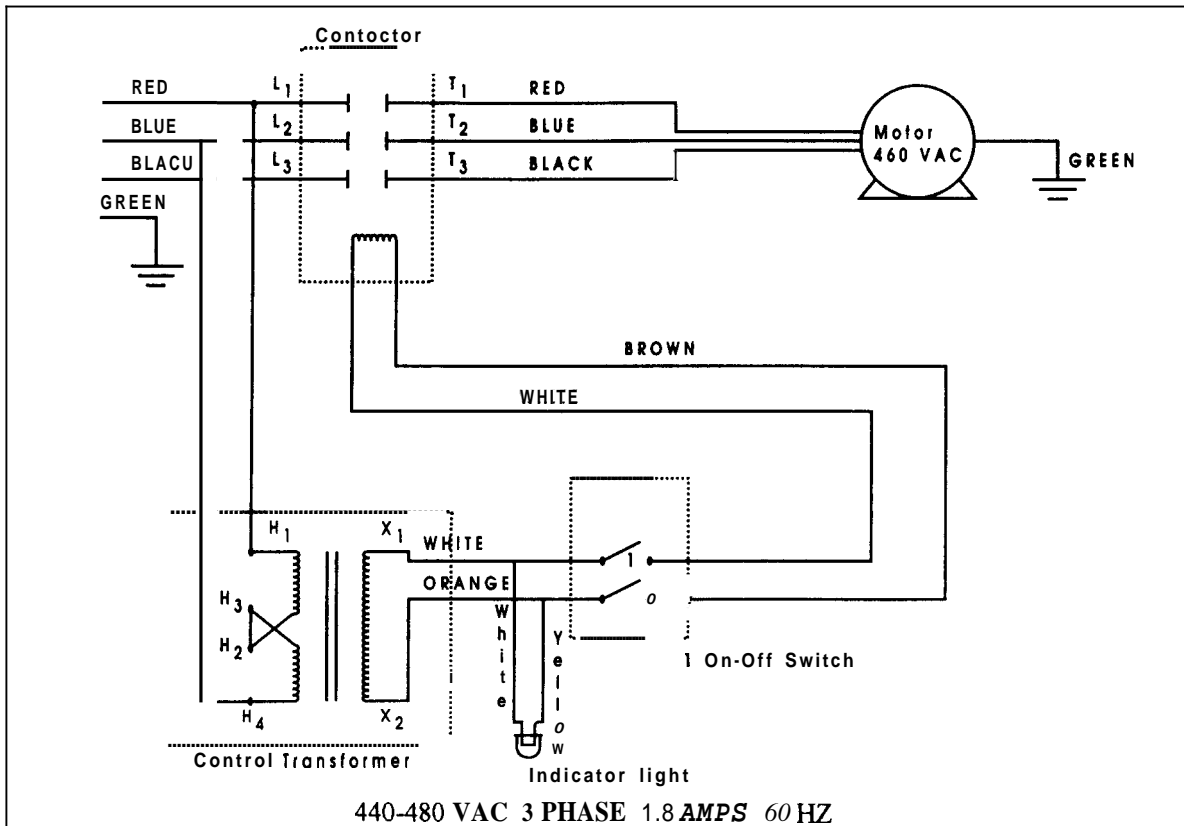
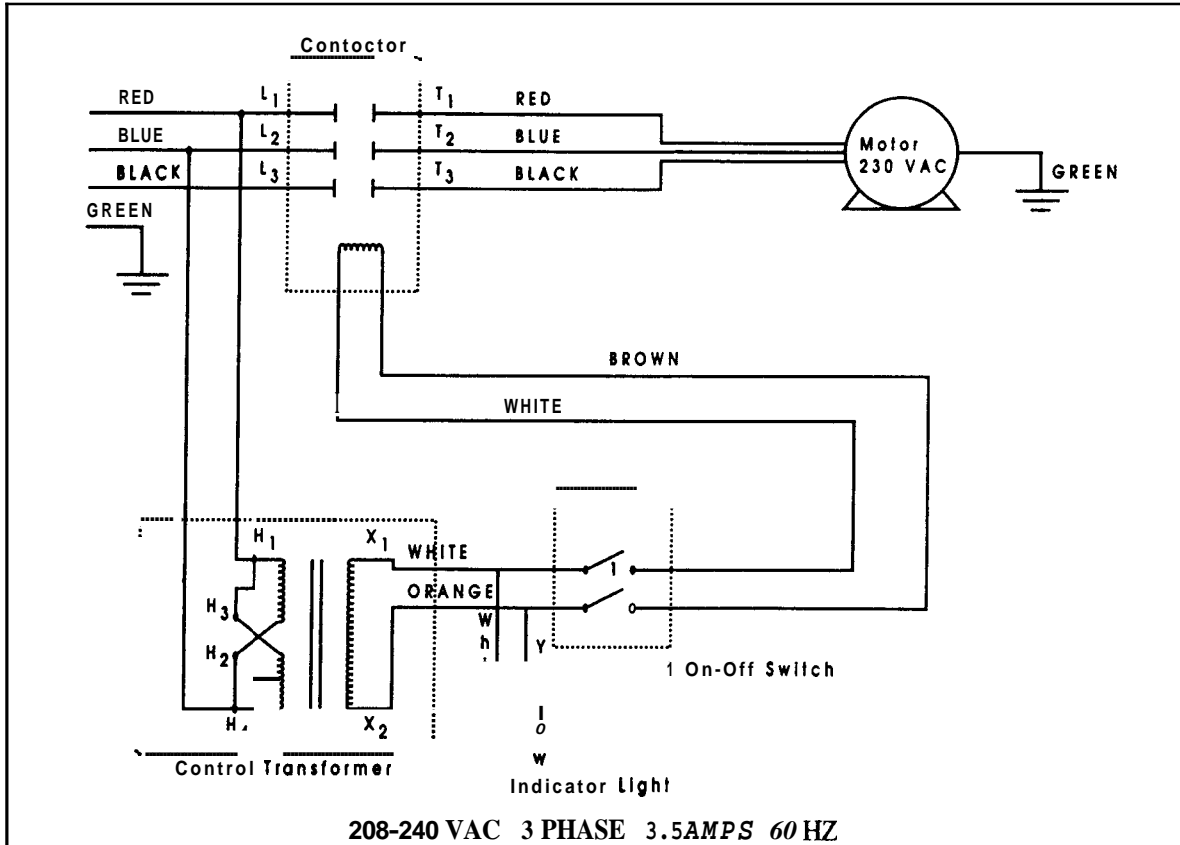

FIGURE 4 - ELECTRICAL SCHEMATIC

SCHEMATICS



PARTS LIST

NO.	DESCRIPTION	PART NO.
1	On/Off switch	10140
2	Indicator Light	10097
3	Ditty Filter Gauge	10205
4	Prefilter, 4" Pleated	41143
5	Blower Sheave	30601
6	Belt	30011
7	Motor, 1 HP, single phase	40013
8	Motor, 1 HP, three phase	40009
9	Blower	37012
10	Exhaust Grille	21326
11	Motor Sheave, Variable	30166
12	Bag Filter, 24" x 24" x 26", 95%	41072
Primary Filter Choices	Bag Filter, 24" x 24" x 26", 85%	41056
	Bag Filter, 24" x 24" x 26", 65%	41055
	Bag Filter, 24" x 24" x 26", 50%	41057
13	Hood	05356
14	Hose, 8" diameter x 10' long	30021
15	Mechanical Arm	05391
16	Strap	30513
17	Casters. Swivel	30041
18	Hose Clamp	30033
19	Springs	30512
20	Contact (3 phase models only)	10078
21	Transformer (3 phase models only)	10075

OPTIONAL EQUIPMENT:

22	Carbon Module, 45 lbs.	07096"
23	Extended Service Filter, 24" x 24" x 12", 95%, 200 sq. ft. Media	41134
Extended Svc. Filter Options	Extended Service Filter, 24" x 24" x 12", 85%, 100 sq. ft. Media	41135
	Extended Service Filter, 24" x 24" x 12", 65%, 100 sq. ft. Media	41139
24	Impinger Assembly	07057

* Extended service filter must be used in place of the standard 26" deep bag filter when used with carbon filter.

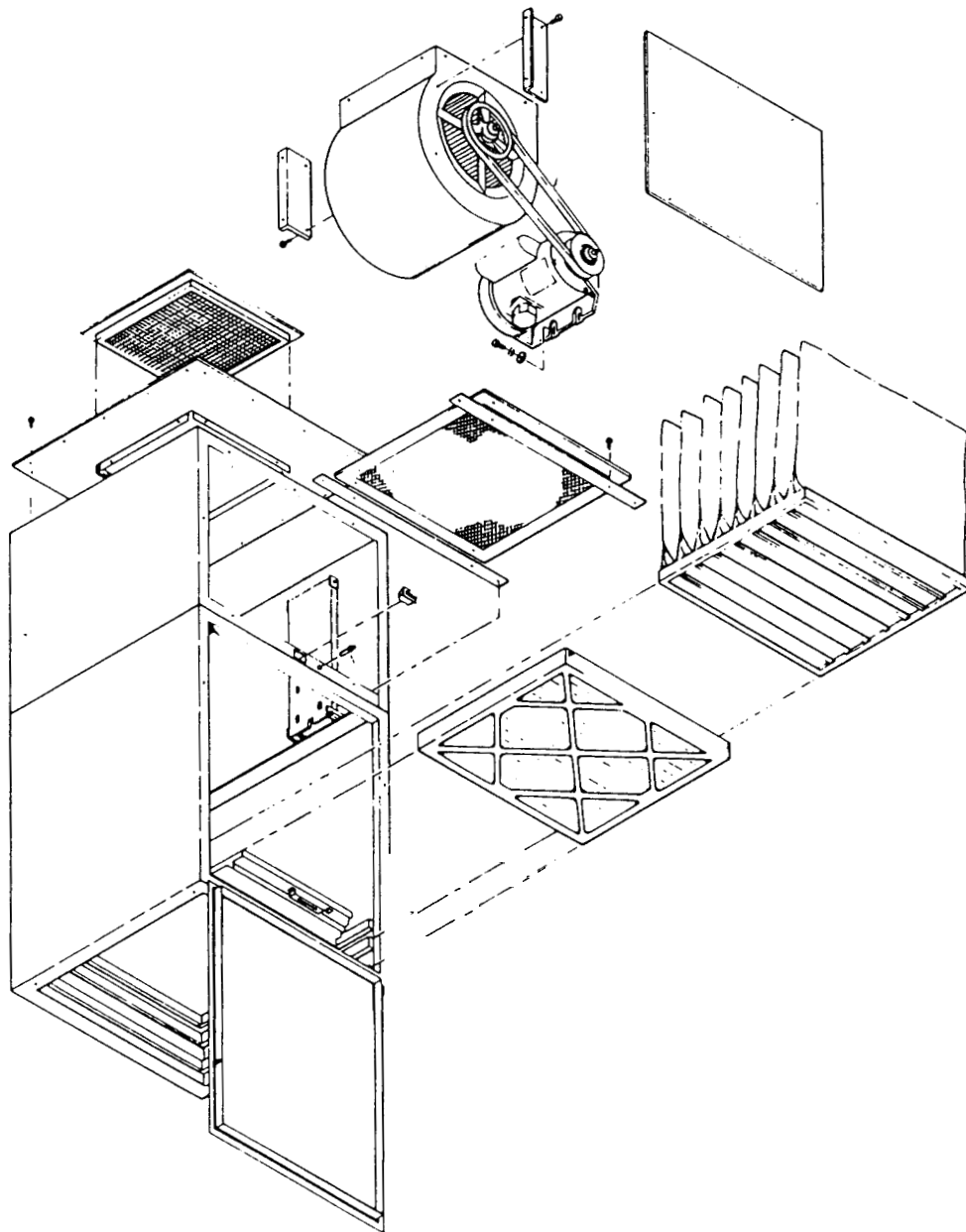

FIGURE 5 - EXPLODED VIEW OF M66V AIR CLEANER