

# **SMOKEMASTER**

## ***F73A and F73B***

### **INDUSTRIAL ELECTRONIC AIR CLEANER**

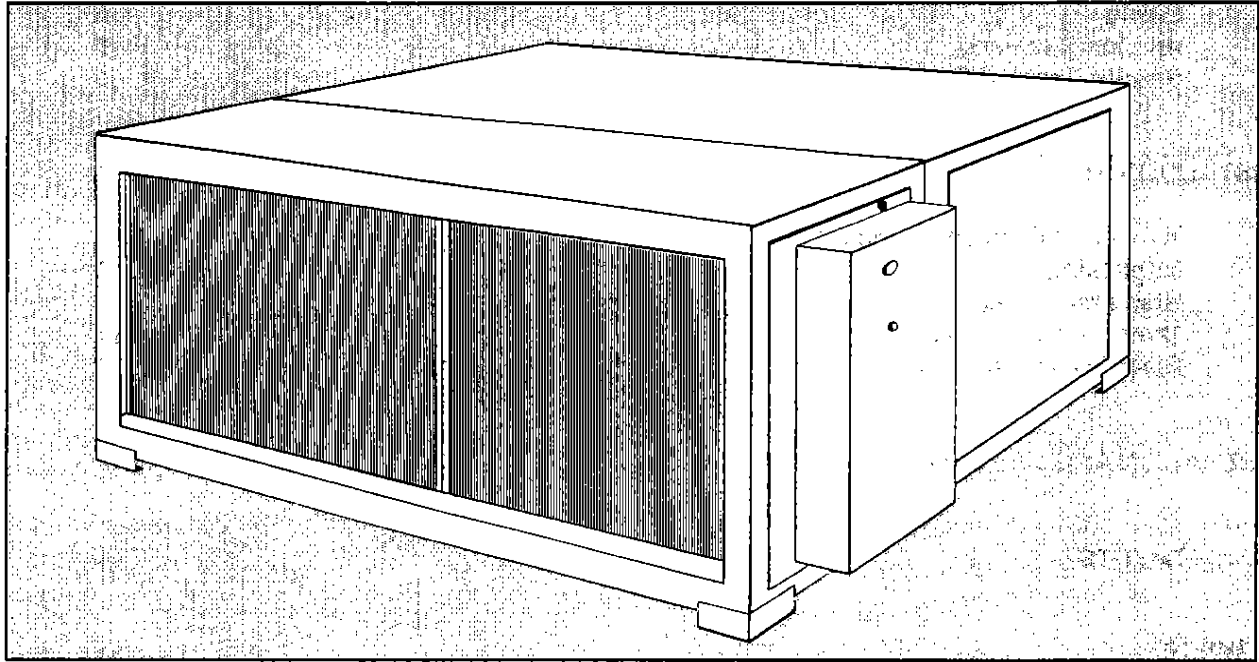

THE F73A AND F73B INDUSTRIAL ELECTRONIC AIR CLEANERS CONTROL WELDING AND METALWORKING FUMES IN WORK AREAS. THEY CLEAN THE AIR OF INDUSTRIAL SMOKE AND OIL MISTS. EITHER SOURCE CAPTURE TECHNIQUES OR AMBIENT AIR CLEANING CAN BE USED TO PROVIDE HEALTHIER WORKING CONDITIONS.

- Adjustable blower circulates up to 5000 CFM of air in the F73A and 6000 CFM of air in the F73B.
- Rated at 80% to 95% efficient according to the National Bureau of Standards Dust Spot Method using atmospheric dust and the ASHRAE Standard 52-76 using atmospheric dust.
- Adjustable discharge grille directs airflow where needed.
- Heavy duty blower and motor use sealed ball bearings for longer life and reduced maintenance.
- Solid state, self-regulating, power supply output is not affected by moderate fluctuations in line voltage. Power supply uses voltage doubler to provide increased ionization voltage.
- Simplified diagnostics using test button and performance system light.
- Single phase operating voltages include 208 Vac, 230 Vac, and 240 Vac. Three phase operating voltages include 208-240 Vac and 440-480 Vac. Fifty Hz models are also available.
- Strong 16 gauge galvanized steel cabinet can be installed on legs or hung from eye bolts which are provided.
- Optional plenum and hoses make source capture application easy.

# TABLE OF CONTENTS

|   | PAGE      |
|---|-----------|
| <b>SPECIFICATIONS</b>                           | <b>3</b>  |
| <b>PLANNING THE INSTALLATION</b>                | <b>6</b>  |
| Introduction                                    | 6         |
| Sizing  | 6         |
| Ambient Cleaning                                | 8         |
| Source Capture Cleaning                         | 8         |
| <b>INSTALLATION</b>                             | <b>11</b> |
| When Installing This Product...                 | 11        |
| Unpacking                                       | 11        |
| Stand Mounting                                  | 11        |
| Overhead Mounting                               | 11        |
| Electrical Installation                         | 12        |
| <b>OPERATION AND CHECKOUT</b>                   | <b>14</b> |
| <b>ADJUSTMENTS</b>                              | <b>14</b> |
| <b>SERVICE</b>                                  | <b>15</b> |
| Cleaning the Electronic Air Cleaner             | 15        |
| Cleaning the Pre/Post Filters                   | 15        |
| The Alkaline Detergent Solution Cleaning Method | 15        |
| Staining  | 15        |
| The Acid Detergent Method                       | 16        |
| Physical Force Methods                          | 16        |
| Contaminants and Cleaning Procedures            | 17        |
| Replacing the Cells                             | 17        |
| <b>TROUBLESHOOTING</b>                          | <b>18</b> |
| <b>PARTS LIST</b>                               | <b>19</b> |

For further information:

**BERRIMAN ASSOCIATES**  
1-800-480-3630  
[www.berriman.com](http://www.berriman.com)

Made With Pride in the U. S. A.

# SPECIFICATIONS

## IMPORTANT

THE SPECIFICATIONS GIVEN IN THIS PUBLICATION DO NOT INCLUDE NORMAL MANUFACTURING TOLERANCES. THEREFORE, THIS UNIT MAY NOT MATCH THE LISTED SPECIFICATIONS EXACTLY. ALSO, THIS PRODUCT IS TESTED AND CALIBRATED UNDER CLOSELY CONTROLLED CONDITIONS, AND SOME MINOR DIFFERENCES IN PERFORMANCE CAN BE EXPECTED IF THOSE CONDITIONS ARE CHANGED.

| MODEL    | VOLTAGE | HP | HZ | PHASE | AMPERAGE<br>MAXIMUM | CFM<br>MAXIMUM |
|----------|---------|----|----|-------|---------------------|----------------|
| F73A1011 | 208-240 | 2  | 60 | 1     | 9.2                 | 5000           |
| F73A1080 | 208-240 | 2  | 60 | 1     | 6                   | 5000           |
| F73A1081 | 440-480 | 2  | 60 | 3     | 3                   | 5000           |
| F73B1080 | 208-240 | 3  | 60 | 3     | 9                   | 6000           |
| F73B1081 | 440-480 | 3  | 60 | 3     | 5                   | 6000           |

### CAPACITY:

The F73 air cleaner is factory set at maximum capacity. If a plenum and ducting are used, it may be necessary to adjust the variable motor sheave to achieve maximum airflow; see Page 14.

### AMBIENT TEMPERATURE RATINGS:

Shipping and storage range is -30° F to +150° F.  
Operating range is +40° F to +125° F.

### WEIGHT:

|            | Shipping | Installed |
|------------|----------|-----------|
| Model F73A | 550 Lbs. | 490 Lbs.  |
| Model F73B | 555 Lbs. | 495 Lbs.  |

### CELL SPECIFICATION:

Both the F73A and F73B models have two cells. The specifications below are for each cell:

Dimensions: 24 1/4" x 24 1/8" x 10 3/4"

Weight: 60 Lbs.

Collection Area: 240 Sq. Ft.

Voltage Gradient: 20,000 volts per inch minimum

### PREFILTER/POSTFILTER:

1" aluminum multilayered mesh -- 23 5/8" x 23 5/8" x 1"

### MOTOR:

Motors are equipped with thermal protection, sealed ball bearings, and a variable motor sheave.

### BLOWER:

Belt driven, dual centrifugal, blower wheels with sealed ball bearings.

**HIGH VOLTAGE POWER SUPPLY:**

Solid state, dual voltage, and self-regulating. Nominal output voltages are 9400 Vdc ionizer and 4700 Vdc on the collector. The high voltage power supply is housed in the hinged power door and is sealed from the air stream.

**CABINET:**

Galvanized steel, 16 gauge

**EFFICIENCY:**

|      | CFM Max. | EFF. | CFM Min. | EFF. |
|------|----------|------|----------|------|
| F73A | 5000     | 90%  | 4200     | 94%  |
| F73B | 6000     | 80%  | 5200     | 91%  |

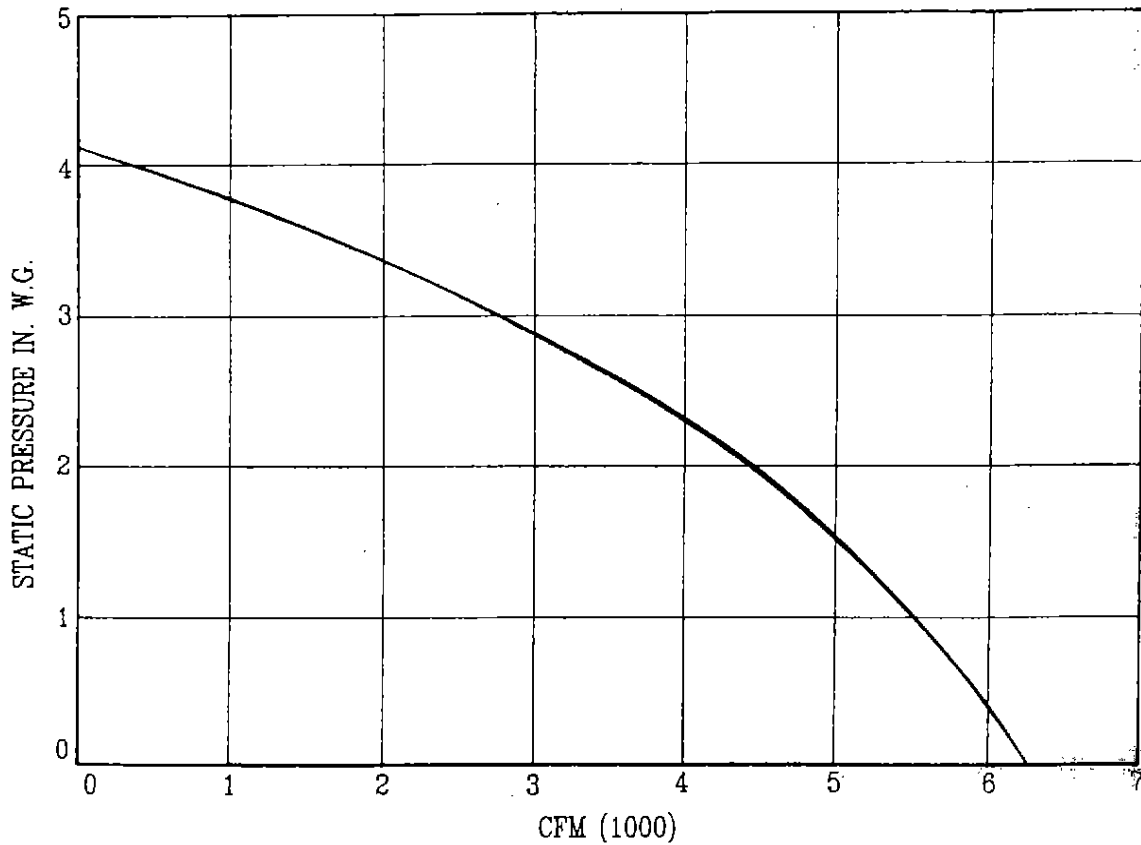

FIG. 2 - F73B SYSTEM BLOWER CURVE

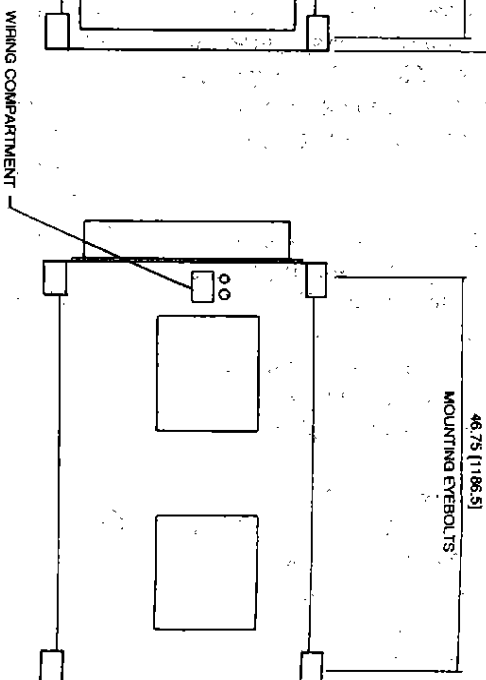
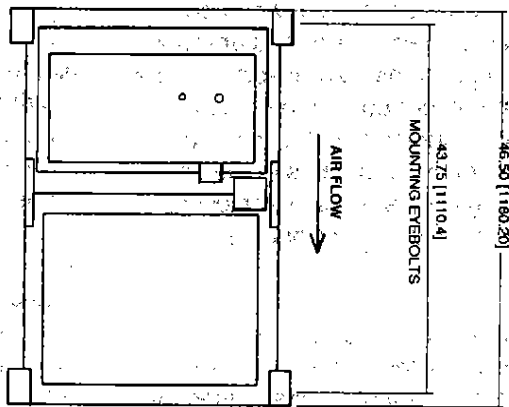
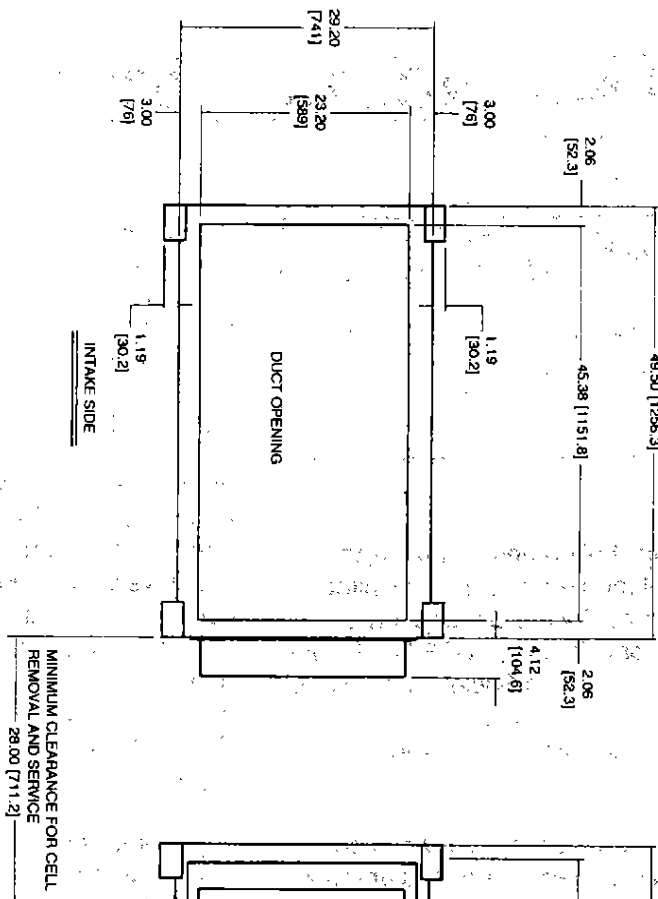

FIG. 1 - F73A AND F73B DIMENSIONS  
[mm shown in brackets]

# PLANNING THE INSTALLATION

## WARNING

The F73A/B Industrial Electronic Air Cleaner is not explosion proof. It must not be installed where there is danger of vapor, gas, or dust explosion.

### INTRODUCTION

Clean air is the subject of numerous laws and regulations. Typical requirements in the United States are those put out by the Occupational Safety and Health Administration (OSHA). Private groups, such as the American Society of Heating, Refrigeration and Air Conditioning Engineers (ASHRAE), have also published numerous recommendations.

Normally, clean air is defined in regulations and recommendations as air having a limited amount of contaminant in it, commonly expressed as parts per million, or milligrams per cubic meter. Approved counteractions are intended to lower or eliminate the amount of contaminants in the air. One of the more common methods of achieving this goal is through the use of electronic air cleaners.

At no time should an electronic air cleaner be placed where there is a potential for explosion due to the presence of explosive dusts, gases, or vapors.

### SIZING

Sizing is that part of the installation which determines how many air cleaning units are required to maintain a desired level of air quality. The process of sizing an application involves roughly calculating the number of air cleaners needed and then modifying the calculation according to the specific characteristics of each application.

If air contaminants are generated from fixed stations where hoods and hoses can be acceptably installed, cleaning the air by capturing the contaminant at the source is strongly recommended. For source capture air cleaning, a hood (not provided) is installed where the contaminants

are generated and an attached hose feeds the contaminants to a source capture plenum. The plenum transfers the contaminants from up to five hoses directly into the electronic air cleaner (hose and plenum are ordered as accessories).

The actual number of contaminant sources which can be conducted into one air cleaner may vary from one to five depending on the nature of the contaminants. The composition, quantity, and rate of generation of the contaminants determines the air velocity needed to effectively capture these contaminants at the source. The required air velocity, in turn, not only affects the hood design and hood location, but it also sets limits on how much hose can be used before the air pressure drop becomes too great for effective contaminant capture.

Therefore, when sizing an application for source capture air cleaning, it is necessary to keep in mind how the specific contaminants, the hood, and the needed velocity all combine to affect the number of stations which can be attached to a single unit and the number of units which will be needed for a particular application.

When the installation of hoods and hoses is physically infeasible or unacceptable, the electronic air cleaners are strategically placed overhead or on stands to provide background air cleaning.

For background air cleaning, the number of electronic air cleaners needed can be estimated by the relationship of air volume to the needed air changes per hour. In these cases, the following formula is helpful:

$$\text{Electronic Air Cleaners} = \frac{\text{Air Volume} \times \text{Air Changes / Hour}}{\text{Clean Air Rating} \times 60}$$

$$\text{Clean Air Rating} = \text{Airflow} \times \text{Efficiency}$$

$$\text{F73A Model} = 5000 \text{ CFM} \times .90 = 4500 \text{ CFM}$$

$$\text{F73B Model} = 6000 \text{ CFM} \times .80 = 4800 \text{ CFM}$$

The air volume in a space is sometimes reduced to account for high ceilings and large equipment in the space. For example, in an application where the ceiling is higher than 30 ft. [9.1 m], the air volume above 30 ft. [9.1 m] may be subtracted if it does not significantly affect contaminant dispersal either by how the contaminants are circulated from their sources or how the heating, cooling, or ventilating equipment affects the dispersment of the contaminants. Also, if equipment takes up a great deal of space in relation to the total air space, its volume may be deducted from the total air volume.

A method for calculating the needed air changes per hour is to measure the generation rate of the contaminants and the suggested allowable level of contamination.

Regardless of the method used to calculate the number of units needed to produce clean air, the physical conditions of the space to be cleared may either limit this number or demand that more units be installed. For background air cleaning it is important to establish a uniform airflow pattern throughout the entire space. Limitations to the calculated sizing may be a lack of space for mounting areas or the number of units may interrupt normal building operation; that is, a unit cannot be mounted where an overhead crane will smash into it or where stand mountings seriously interrupt building traffic patterns. The number of units required by air volume and air changes per hour might need to be increased when the shape of a structure is such that effective capturing and air distribution is not possible according to the sizing calculations.

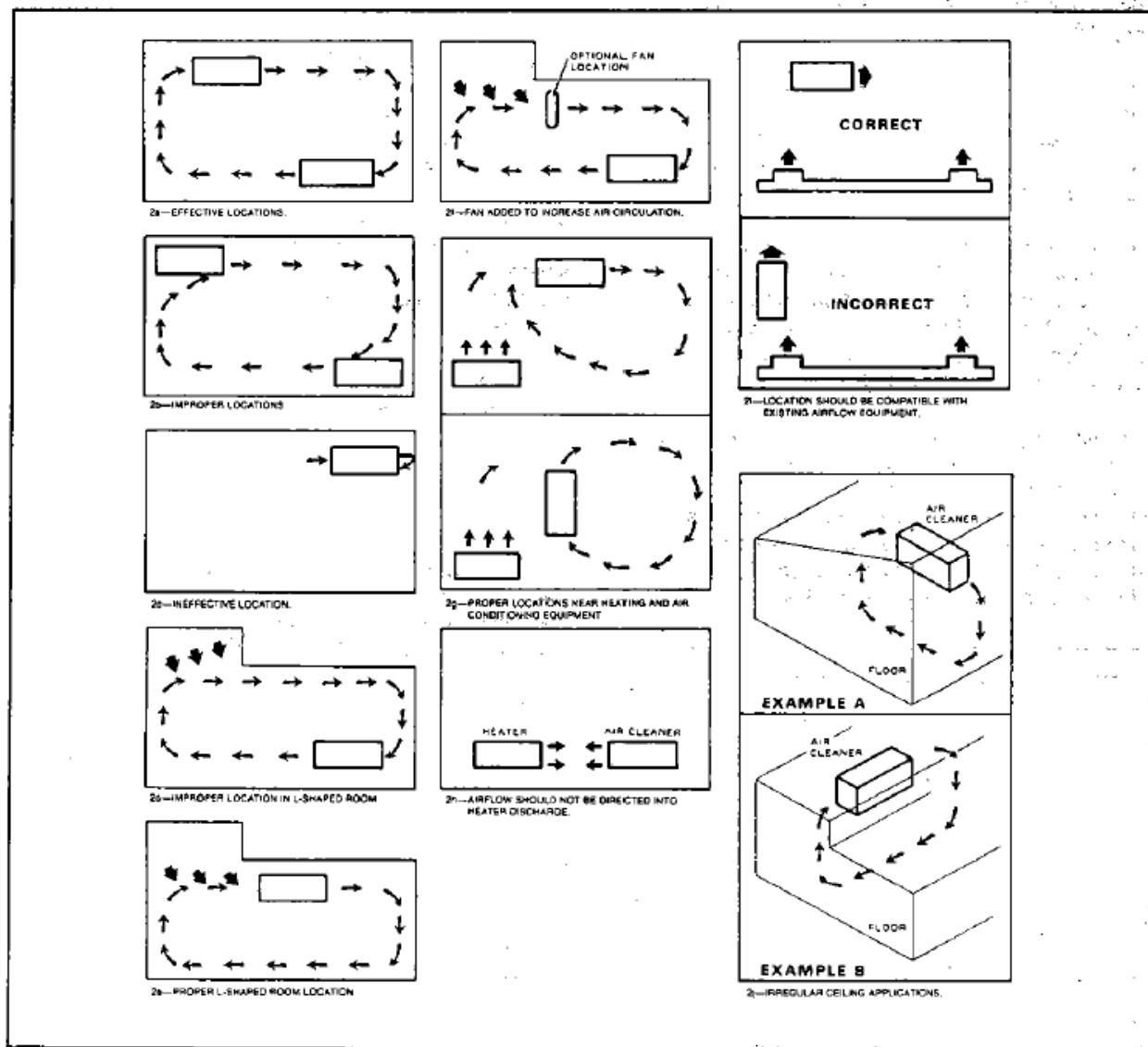

FIG. 4 - GUIDELINES FOR LOCATING THE F73A/B WHEN AMBIENT CLEANING.

## AMBIENT CLEANING

Whether an air cleaner is ceiling hung or placed on a stand, the first important consideration is that the inlet of the unit be located as close as is reasonably possible to the greatest concentration of air contaminants. Second, since the air cleaner draws contaminated air from approximately 10 ft. [3 m] around the outlet and exhausts the cleaned air from 50 to 75 ft. [15.2 m to 22.8 m] from the outlet, the inlet of the unit should be placed 25% of the distance along the wall of a room. See Fig. 3.

DO NOT locate an air cleaner inlet too close to the corners of a room. Contaminated air will be able to bypass the unit and not be cleaned. DO NOT locate an air cleaner outlet too close to a corner or wall. See Fig. 2 (2c). The cleaned air will recirculate directly back to the air cleaner inlet.

DO NOT locate an air cleaner in an L-shaped room so that exhausted air enters directly into the small portion of the room as shown in Fig. 2 (2d). This can produce a self-contained circular air pattern in the small part of the room which decreases the air cleaner's effectiveness. Locate an air cleaner in an L-shaped room as indicated in Fig. 2 (2e).

The shape of a room and location restrictions may require the installation of a fan as in Fig. 2 (2f) to promote proper air circulation. Also, the size of a room may require the use of fans to bring contaminants to an air cleaner inlet.

In rooms with irregular ceilings, install the air cleaner close to the ceiling on the highest wall as Example A indicates in Fig. 2 (2j). When one section of the ceiling is at least 12 in. [3-4.8 mm] higher than another, locate the air cleaner in the area with the higher ceiling as shown in Example B of Fig. 2 (2j).

When selecting locations for numerous units, position the air cleaners to create uniform movement of air and provide maximum access to the sources of contamination. The outlets of the air cleaners should not be located so that they generate opposing air currents or that the outlet from one air cleaner is less than 30 ft. [9.1 m] from the inlet of another air cleaner.

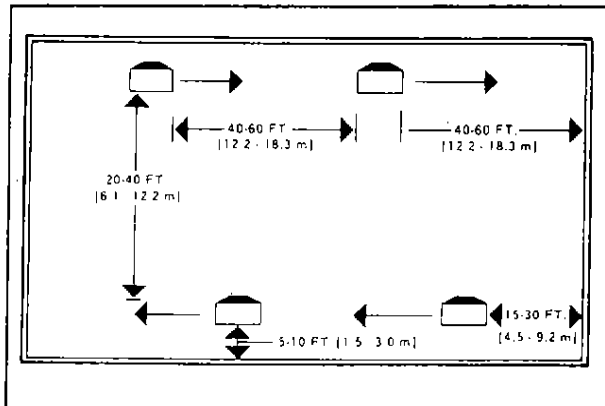

FIG. 5 - LOCATION GUIDE FOR BACKGROUND CLEANING

## SOURCE CAPTURE CLEANING

When selecting a location for an electronic air cleaner that uses a hood and hose to capture the contaminants at the source, note the available stand or ceiling mounting areas which will provide satisfactory air distribution for the air cleaner outlet. Choose the location which will keep the air pressure drop, caused by the length of the hose, within an acceptable range. Do not mount the outlet of the air cleaner so close to a wall that it inhibits the airflow. Also, the outlet of an air cleaner should not be located such that it interferes with the source capture process of another air cleaner hood.

To effectively control atmospheric contamination at its source, proper hood design is necessary. Minimum airflow and power consumption are also important factors in designing an effective local exhaust system to control contamination.

Capturing air contaminants at their source requires the creation of sufficient airflow past the contaminant source to remove the contaminated air and draw it into an exhaust hood. Fine airborne dust particles, mists, vapors, gases, and fumes follow air currents. Airflow, alone, is sufficient to capture these contaminants.

Larger dust particles tend to have a trajectory, or throw, in air. Capturing these heavier particles calls for barriers and proper hood placement to direct the particles into the hood before they fall out of the airstream. This placement should also prevent particle scattering.

Basic knowledge of the contaminated airflow to be controlled is necessary before an effective hood or enclosure can be designed. The more complete and effective the design, the more economical and efficient the installation will be.

A complete enclosure is often the best way to start. Once a source is ideally enclosed, provide access and working openings as required. This concept can be used to develop booths, side- or down-draft hoods, and side shields.

The access and working openings must be kept to a minimum. Whenever possible, they must also be kept away from the contaminated airflow. Any inspection and maintenance openings should be provided with tight doors whenever possible.

A hood that is open and does not enclose or confine the contaminant should be avoided. Open hoods can be used, but exhaust volumes must be large and cross drafts nearby can easily upset draft control.

Canopy hoods are effective in controlling operations that may suddenly release surges of gases and vapors. Hot processes are an example.

However, canopies should not be used where people may be working in the airflow between contaminant source and canopy because exhaust airflow can actually increase the worker's exposure to the contaminant. Plating tanks and cementing tables typically have this problem with canopy type hoods.

The duct takeoff in the exhaust hood should be located in the normal line of contaminant travel. Arrange the duct openings to distribute the exhaust airflow throughout the hood. This is especially important with large shallow hoods where air movement tends to concentrate close to the duct opening. The airflow can be spread around the hood by using multiple duct takeoffs, interior baffles, or filter banks.

Air intake from areas not needing airflow or without contaminants can be controlled with flanges. Flanges minimize airflow from areas outside the desired air collection area. Usually the flange width is equal to the hood diameter but not exceeding 6 in. [152.4 mm]. Flanges may increase the effectiveness of the hood, allowing a reduction in hood airflow requirements by

up to 25 percent.

Exhaust airflow requirements are calculated after the hood design is determined. The airflow volume is calculated using the enclosure's known open area and the airflow velocity needed to collect the contaminants. The collected airflow must be sufficient to prevent the escape of any contaminated air. Table 1 shows airflow capture velocities for various types of processes.

Where enclosing the process is impractical, the hood should be located as close to the source as possible. The airflow must be adequate to maintain the capture velocity required to carry the contaminants to the hood opening. See Fig. 4.

**TABLE 1 - CONTAMINANT CAPTURE VELOCITIES\***

| CONTAMINANT DISPERSAL CONDITION                                       | EXAMPLES  | CAPTURE VELOCITY |                     |
|---|---|------------------|---------------------|
|   |   | fpm              | m <sup>3</sup> /hr. |
| Released with practically no velocity into quiet air.                 | Evaporation from tanks, degreasing, etc.  | 50-100           | 914-1829            |
| Released at low velocity into moderately still air.                   | Spray booths, intermittent container filling, low speed conveyor transfers, welding, plating, pickling. | 100-200          | 1829-3658           |
| Active generation into zone of rapid air motion.                      | Spray painting in shallow booths, barrel filling, conveyor loading, crushers.                           | 200-500          | 3658-9144           |
| Released at high initial velocity into zone of very rapid air motion. | Grinding, abrasive blasting, tumbling.  | 500-2000         | 9144-36576          |

In each category above, a range of capture velocity is shown. The proper choice of values depends on several factors.

Lower End of Range

1. Room air currents minimal or favorable to capture.
2. Contaminants of low toxicity or of nuisance value only.
3. Large hood-large air mass in motion.

Upper End of Range

1. Disturbing room air currents.
2. Contaminants of high toxicity.
3. High production, heavy use.
4. Small hood-local control only.

\*From INDUSTRIAL VENTILATION MANUAL by the American Conference of Governmental Industrial Hygienists.

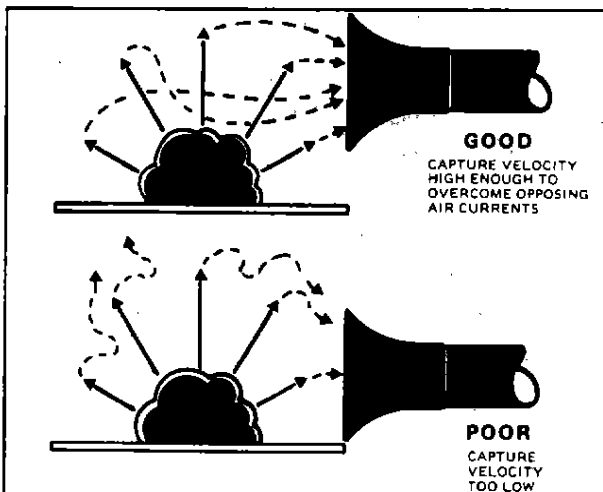

**FIG. 6 - CAPTURE VELOCITY**

Collecting contaminants is accomplished by eliminating or minimizing natural air currents at the contaminant site, and by pulling the air into the exhaust hood. The airflow velocity must be high enough to overcome any opposing air currents and maintain the capture velocity. See Fig. 4.

Source of air motion to either minimize or use to advantage in hood design:

- Thermal air currents from heat generating operations.
- Machinery motion (conveyor belts, grinders, etc).
- Material motion (dumping or container filling).
- Operator movements.
- Room air currents (generally 50 fpm [85 m<sup>3</sup>/hr.] minimum; could be much higher.
- Spot heating, cooling or ventilation equipment near area.

See Fig. 5.

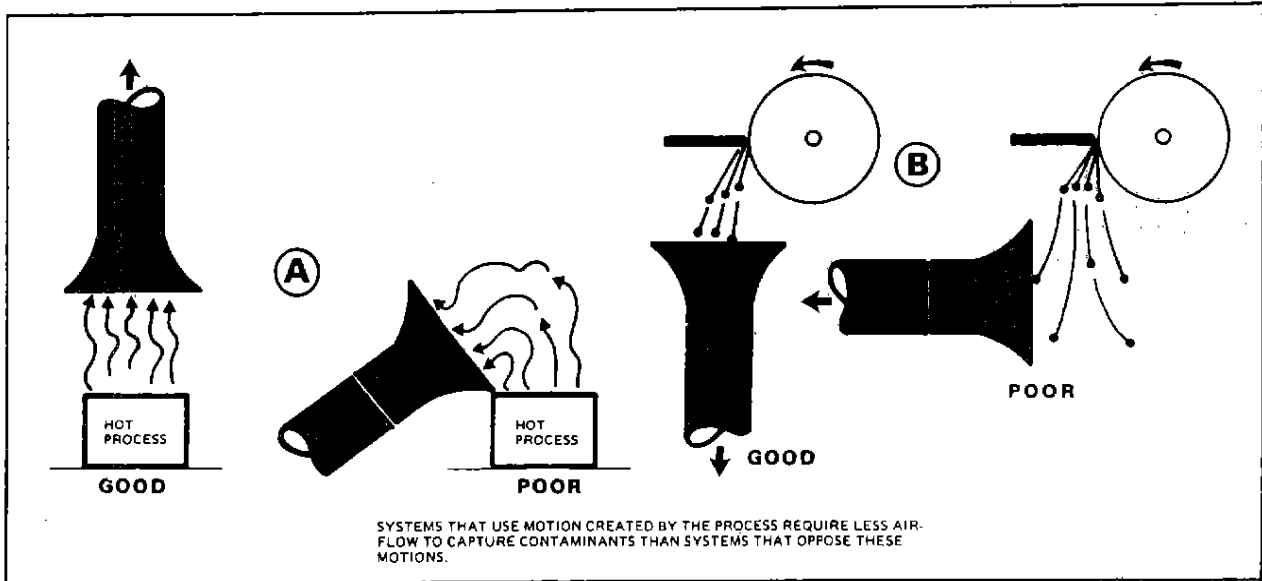

FIG. 7 - UTILIZING PROCESS MOTION

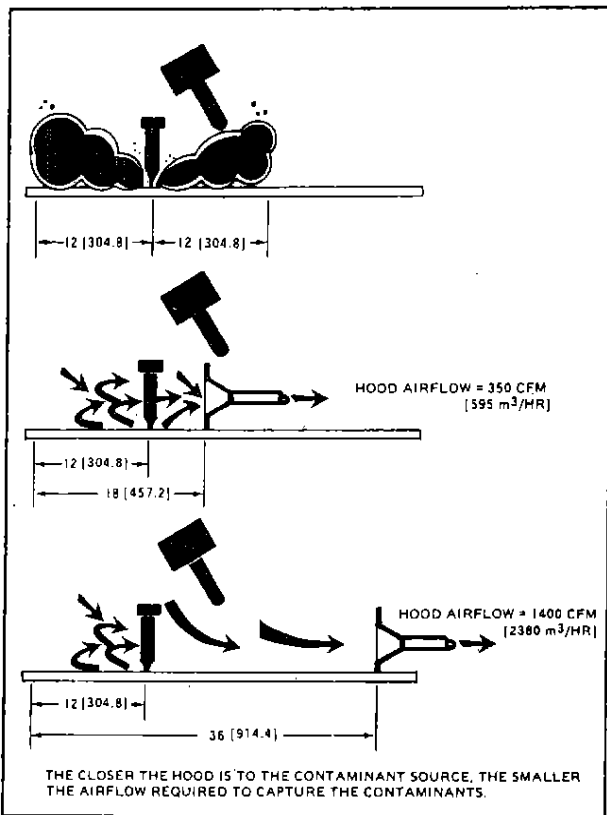

FIG. 8 - HOOD LOCATION; AIRFLOW NEEDED INCREASES WITH DISTANCE FROM WORK.

Airflow needed in a hood design is affected by hood shape, size, and location. The hood should be as close as possible and enclose the operation as much as possible.

Suction in a duct opening will draw in air equally from all directions. As the distance from the inlet opening increases, the decrease in airflow velocity occurs more quickly.

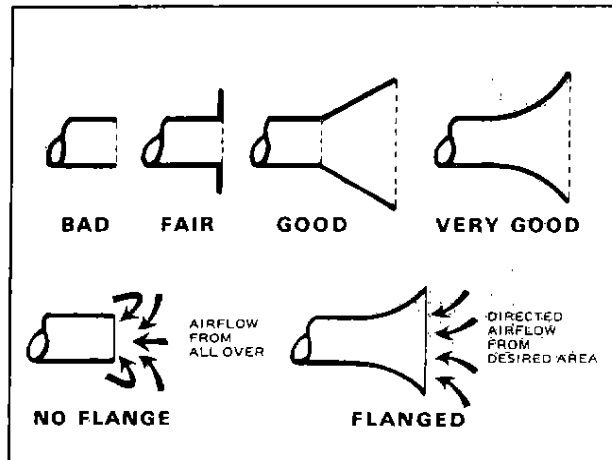

FIG. 9 - HOOD FLANGES

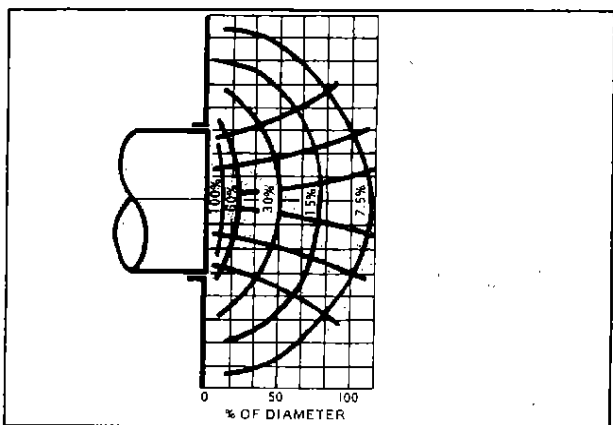

FIG. 10 - VELOCITY CONTOUR (IN PERCENTAGE OF OPENING VELOCITY) FOR FLANGED CIRCULAR OPENING.

When utilizing thermal airflow occurring in a process, exhaust airflow should be greater than the process airflow. This will minimize air spillage at the rim of the hood.

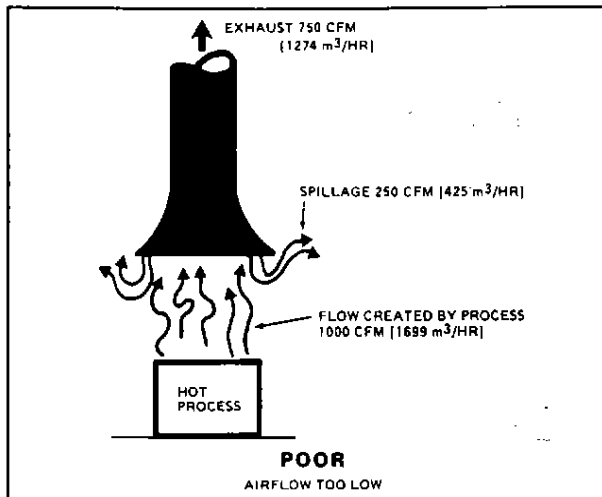

FIG. 11 - MAINTAIN ADEQUATE AIRFLOW.

For further information on ventilation and hood design, refer to a more complete source, such as:

**INDUSTRIAL VENTILATION**, by the American Conference of Governmental Industrial Hygienists, published by the Committee on Industrial Ventilation, Lansing, Michigan, 48106.

**HANDBOOK OF VENTILATION FOR CONTAMINANT CONTROL**, by Henry J. McDermott, published by Ann Arbor Science, Box 1425, Ann Arbor, Michigan, 48106.

## INSTALLATION

### WHEN INSTALLING THIS PRODUCT...

1. Read these instructions carefully. Failure to follow them could damage the product or cause a hazardous condition.
2. Check the ratings given in the instructions and on the product to make sure the product is suitable for your application.
3. Installer must be a trained, experienced service technician.
4. After installation is complete, check out product operation as provided in these instructions.

### CAUTION

1. Do not connect the power source until after the electronic air cleaner is mounted. This will prevent electrical shock or equipment damage.
2. Be sure to turn the air cleaner off before servicing it. The air cleaner motor is equipped with an automatic thermal overload. Should the motor become overheated, it will automatically stop. It will automatically start after a sufficient period of cooling (several minutes to an hour.)
3. If the air cleaner must be turned on for an electrical check, be extremely careful in avoiding electrical shock. Also, take care when working near the air cleaner's moving parts.

### UNPACKING

The F73 mounting brackets and hardware are packed in one box. Check all air cleaner components carefully when unpacking. Remove all shipping cardboard. Be sure to inspect all packing materials before discarding them.

### OVERHEAD MOUNTING

When installing the F73 in an overhead location, position the air cleaner as close to the contaminant source as possible. This increases the air cleaner's effectiveness. It is important to select an overhead mounting location for the air cleaner which provides easy access for cell cleaning and maintenance. Do not place a ladder against the air cleaner, when it is mounted overhead, in order to gain access to the air cleaner interior.

The overhead structure must be strong enough to support twice the weight of the F73. Do not fasten the F73 to a false ceiling or to plaster or plaster board. In some cases it may be necessary to construct supports which will bear the weight of the F73.

Install the F73 using the 3/8" eyebolts provided with the air cleaner. Refer to Fig. 1, Page ? for spacing of the eyebolts. Be certain that the mounting apparatus (not included) from the eyebolts to the ceiling provides adequate strength and stability. The mounting apparatus must be attached securely to the overhead structure. The F73 must be supported by all four eyebolts. See Fig. 12.

### STAND MOUNTING

Securely place the F73 on an appropriate stand or cart and locate as close to the contaminant source possible. The position should also allow satisfactory distribution of air from the outlet of the air cleaner. If a source capture hood, plenum, and hose are used, observe the instructions in **PLANNING THE INSTALLATION** for selecting a suitable location for the unit.

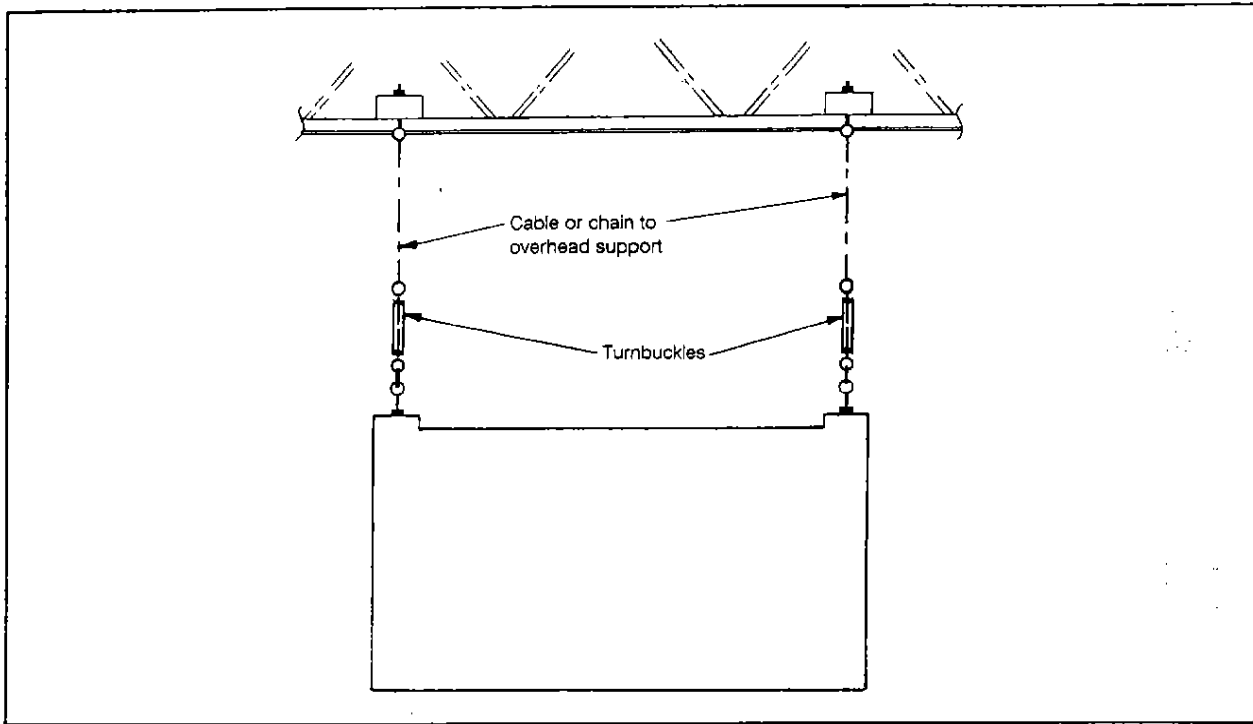

**ELECTRICAL INSTALLATION**

**CAUTION**

This procedure should be attempted only by persons qualified to install electrical wiring. All wiring must comply with applicable codes and ordinances. Be sure the power source is compatible with the model ordered.

It is recommended that No. 12 wire or heavier be used to complete the wiring from the F73 to the wiring compartment to the external power source. However, be certain to comply with local codes. A green wire is provided in the wiring compartment for a grounding connection. Proper grounding of the F73 is mandatory for proper operation and safety.

**STEP 1**

Remove the wiring compartment cover. The wiring compartment is located on the exhaust end of the F73.

**STEP 2**

One-half inch or three-fourths inch conduit can be used for the wire raceway to the F73 wiring compartment.

**STEP 3**

Run No. 12 gauge or heavier wires to the F73. Use wire nuts to make the connections as per

Fig. 13 for 208-240 Vac single phase models, and Fig. 14 for three phase models.

**STEP 4**

Reattach the wiring compartment cover.

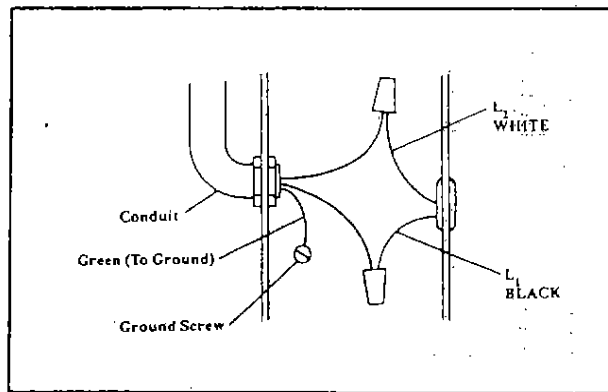

**FIG. 13 - SINGLE PHASE**

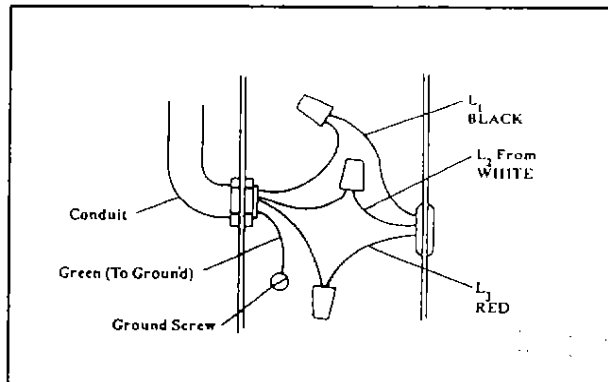

**FIG. 14 - THREE PHASE**

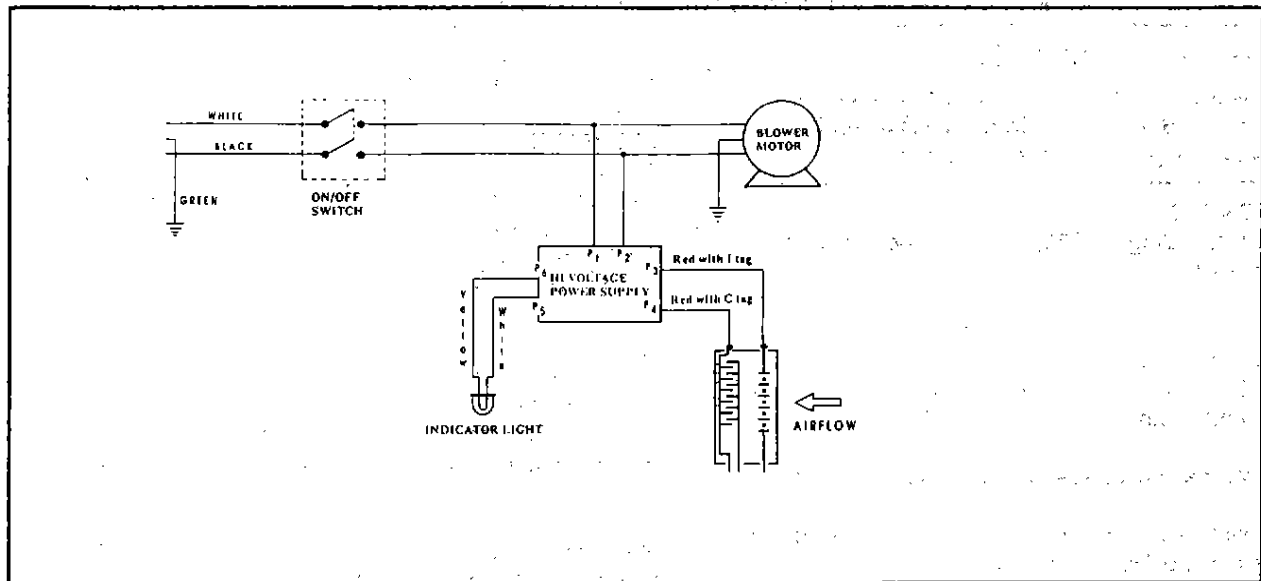

- SCHEMATIC F73, 208-240 VAC, 1 PHASE

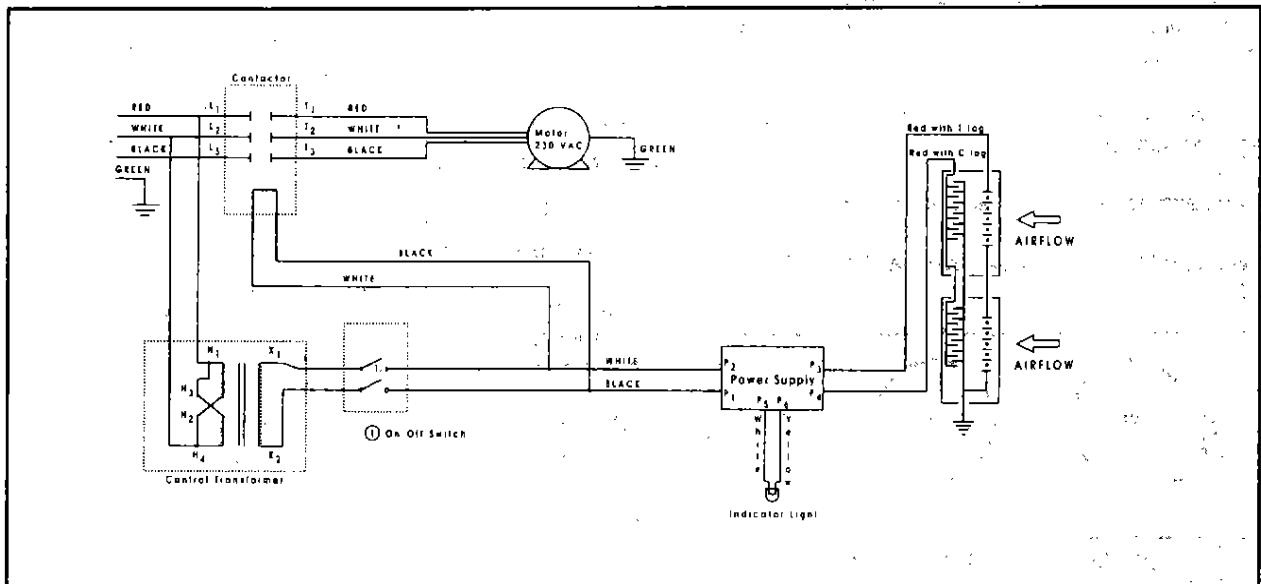

- SCHEMATIC F73, 208-240 VAC, 3 PHASE

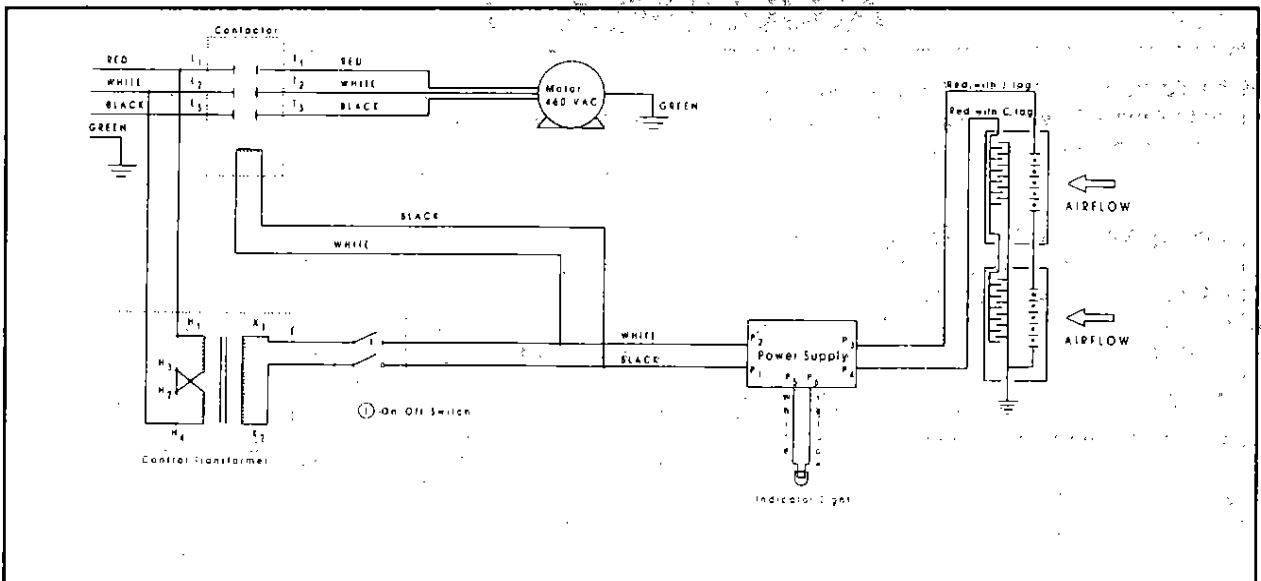

- SCHEMATIC F73, 440-480 VAC, 3 PHASE

# OPERATION AND CHECKOUT

## IMPORTANT

Check for correct blower rotation on three phase models. See Fig. 22. Correct by interchanging any two of the power supply connections.

### CHECKOUT

Before operating the F73, check out the installation using the following procedure:

1. Observe that the air cleaner is positioned for good air circulation where it will not interfere with personnel and material traffic. Keep out of fire lanes and away from overhead cranes.
2. Note that the access door can be easily opened.
3. Check that the F73 is securely mounted overhead or in a stable position on the accessory stand.
4. Check that the electronic cells are correctly positioned, the airflow arrows are pointing toward the blower, and the handles are near the access door hinges.
5. Observe that the prefilter and postfilter screens are correctly positioned.
6. Check and adjust the belt tension, if necessary.
7. Make sure the junction box cover has been reinstalled.

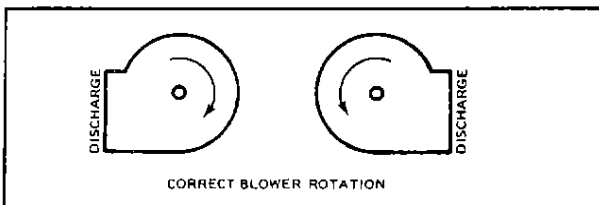

FIG. 22 - BLOWER ROTATION

8. Clean up the inside of the cabinet, the outside of the cabinet, and the installation area.

### OPERATION

When the electronic air cleaner is energized, the blower produces an airflow velocity which conveys contaminated air into the air cleaner inlet. Particles that are too small to be caught by the prefilter screen are given an intense electrical charge in the ionizing section of the electronic cell. As the air carries these charged particles into the collecting section of the electronic cell, they are hurled against metal plates by the force of a powerful electrical field. These particles cling to the metal plates, and the air passes through a postfilter screen and the blower compartment and reenters the building space as cleaned air.

Start up the air cleaner with the access doors properly closed. Put the rocker switch in the ON position. Check for the following:

1. The blower should be providing a strong discharge airflow. ON THREE PHASE MODELS, THE BLOWER SHOULD BE ROTATING IN THE DIRECTION SHOWN IN FIG. 22. If it isn't, correct rotation by interchanging any two power supply leads.
2. The performance indicator light should be on when the blower is running.
3. Push the test button to momentarily short out the collector section of the electronic cells. Arcing indicates that the cells are energized properly.
4. Opening the access door should turn off the performance indicator light. Do not place a ladder against the air cleaner, when it is mounted overhead, in order to gain access to the air cleaner interior.

# ADJUSTMENTS

Adjust the bidirectional louvers of the air cleaner discharge so that the airflow discharge does not produce discomfort or a possible hazard to personnel and equipment.

The blower capacity of the F73 is factory set. See Specifications on Page 3. This capacity can be adjusted. Before adjusting the blower capacity, make sure that the ON-OFF switch is in the OFF position. To adjust the blower capacity:

1. Turn the air cleaner off and open the access door to the blower and motor section of the air cleaner.
2. Loosen the two bolts locking the end of the motor rail in position. Remove the belt.
3. Loosen the allen setscrew on the face of the motor sheave.

4. Rotate the sheave into a position which gives the desired blower capacity.

**NOTE:** When the sheave is rotated all the way into the shaft, the blower capacity is at its maximum. When the sheave is rotated five turns out on the shaft, the blower capacity is at its minimum. DO NOT ROTATE THE ADJUSTABLE SHEAVE MORE THAN FIVE TURNS OUT ON THE SHAFT. The sheave may already be adjusted one or more turns out on the shaft.

## CAUTION

Adjusting the variable sheave changes the load on the motor. Do not exceed the rated amperage for the motor.

5. Make sure that the sheaves are in line. If not, loosen the motor and blower sheaves and align them properly. Tighten the sheaves securely.

6. Replace the belt and retighten the bolts in the motor rail. The belt should be tightened enough to prevent slippage but not so tight that vibration occurs. The correct tension results in a 3/4 to 1 in. [19.1 to 25.4 mm] deflection when a 10 lb. [4.5 kg.] force is applied to the

center of the belt span.

7. Close the access door and energize the air cleaner.

**NOTE:** For some blower adjustments, it may be necessary to use a smaller belt instead of the existing belt to achieve proper tension. Generally a 1 in. [25.4 mm] shorter belt will be required.

## SERVICE

### CLEANING THE ELECTRONIC AIR CLEANER

The F73 is used to remove a variety of contaminants from the air. In the process of cleaning the air, however, parts of the air cleaner will become dirty and the cleaning efficiency will be lowered.

In order to maintain a high standard of reliability and efficiency, it is necessary for the F73 to receive periodic maintenance. Periodic maintenance means cleaning the electronic cells and inspecting the electronic air cleaner both visibly and with instruments. Service will be required if the air cleaner seems damaged or appears to be performing at substandard efficiency.

Manufacturer recommends regular cleaning and the use of an alkaline detergent solution. The exact scheduling is a matter of experience since each air cleaning situation varies. Actual experience may dictate a greater or lesser period between cleanings.

If the alkaline detergent solution proves inadequate because of excessive buildup of captured contaminants, the use of physical force (such as, high pressure air, water, or steam) or an acid detergent solution may be required.

## CAUTION

1. Be extremely careful when working with F73 cells and filters. The edges of the cells and filters, and the collection plates and ionizing wires of the cell may be sharp.
2. When cleaning the cells and filters be sure to wear appropriate protective gear, especially goggles and gloves. Skin contact with either alkaline or acid detergent solution should be avoided.
3. Electronic air cleaners and their components are susceptible to damage. Take care when working with them to avoid equipment damage.

### CLEANING THE PRE/POSTFILTERS

Remove the pre/postfilter and shake out or vacuum the accumulated contaminants. The pre/postfilter can also be soaked in the alkaline detergent solution, or use high pressure water, air, or steam cleaning on the pre/postfilter.

**NOTE:** If the pre/postfilter needs washing, wash it after

the cell(s) have been washed. The lint residue from the pre/postfilter will contaminate the wash water and can deposit inside the cell(s). Dispose of the wash water.

### THE ALKALINE DETERGENT SOLUTION CLEANING METHOD

**NOTE:** Be careful to avoid prolonged skin contact with the solution. DO NOT SPLASH SOLUTION IN YOUR EYES.

1. Provide a container large enough to hold the electronic cell to be cleaned.
2. Fill the container sufficiently with detergent and hot water to cover the electronic cell.
3. Soak the cells in the solution for about 15 minutes. The solution should be agitated in some way, such as, sloshing the cells or stirring the solution.
4. Remove the cells from the alkaline cleaning solution and place them in another container of hot water (150° F to 170° F [66° C to 77° C]) for rinsing. The cells should be rinsed for 5 to 10 minutes.

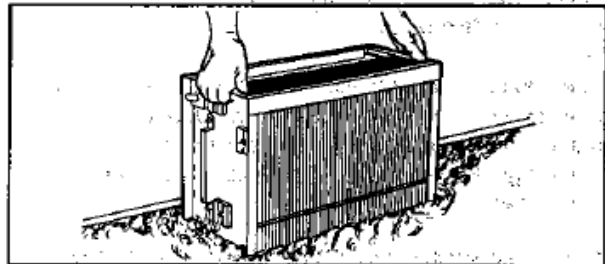

FIG. 23 - WHEN SOAKING THE CELL, AGITATE THE WATER.

5. Remove the cells from the rinse water. Allow the cells to drain and dry before energizing them.

### STAINING

Occasionally after the soaking process, the cell or pre/postfilter may seem stained. If the stain is black or very dark, it is probably detergent residue and should be rinsed off at once. Detergent residue may affect the electronic air cleaner's efficiency.

If yellowing appears, it is probably staining. The acid detergent will remove the yellowing. However, it should be noted that the yellowing does not affect air cleaner efficiency.

## THE ACID DETERGENT METHOD

Manufacturer does sell an acid detergent; however, acid cleaners should be used only after alkaline detergents have proven inadequate. Acid detergents have been tested and proven to be corrosive. They will decrease the life of the cells. If an acid detergent solution is used, be sure to use a weak mixture. DO NOT place pre/postfilters in an acid detergent solution.

### IMPORTANT

Acid detergents *must* be properly handled. Refer to the label on the acid detergent used. This means wearing protective clothing, rubber gloves and goggles, and reading all precautions on the label of the detergent used. If contact is made in the eyes, flush with large amounts of water and consult a physician.

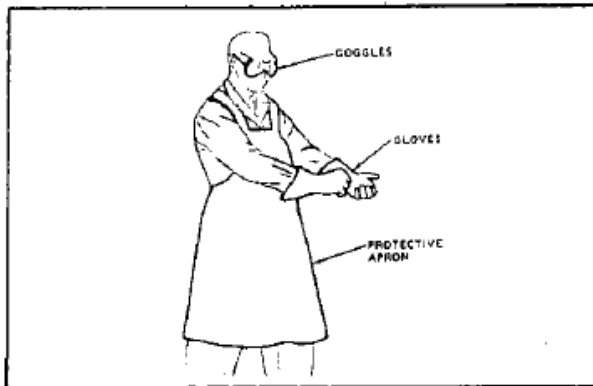

FIG. 24 - BE SURE TO WEAR THE PROPER EQUIPMENT FOR WORKING WITH DETERGENT SOLUTIONS.

**NOTE:** Be sure to provide adequate ventilation when using acid detergents.

After the cleaning process is completed, the soak water must be neutralized according to the U. S. Environmental Protection Agency and state and local pollution control guidelines and requirements. Soda ash is one neutralizer.

1. Use a polyethylene or Type 36 stainless steel container large enough to hold the electronic cell. Other types of containers should be avoided since the acid detergent may react with the container material.
2. Following the instructions for temperature of the water and amount of acid detergent used, prepare the cleaning solution. The amount of detergent and the soaking time will be determined by the amount of contaminants captured by the cells and the difficulty encountered in removing the buildup. The usual mix for acid solution is 2 oz. of acid detergent to 1 gal. of water [59.2 ml to 3.8 L].

**NOTE:** It is recommended that acid cleaning of any electronic air cleaner cells containing metal oxide contaminants be performed with room temperature or cold water. NEVER add acid detergent to hot water.

3. Be sure to observe the cleaning operation when the cells are placed in the acid detergent solution. The amount of acid detergent should be reduced if less than 30 seconds pass before large amounts of bubbles are released. The cells should NOT remain in the acid detergent solution more than 30 seconds after vigorous reaction begins. It is a good idea to remove the cells and inspect the cleaning action of the acid detergent solution. If contaminant deposits remain, the cells can be returned to the solution.

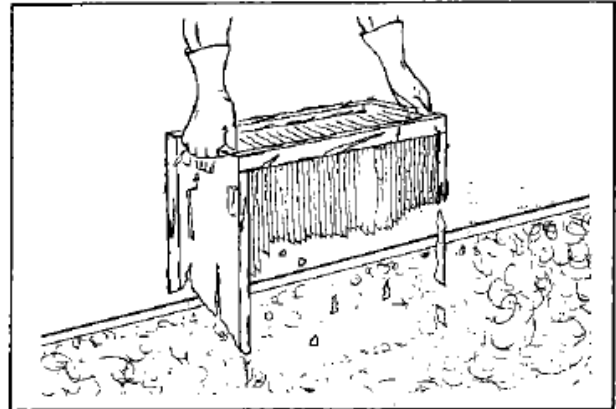

FIG. 25 - TOO MUCH TIME IN THE ACID SOLUTION WILL HARM THE ELECTRONIC CELL.

### IMPORTANT

After the contaminants are removed by the acid detergent solution, any further time the cells remain in the solution serves only to decrease their life.

4. After removing the cells from the acid detergent solution, rinse them thoroughly for at least five minutes.
5. Allow the cells to drain and dry before energizing them.

## PHYSICAL FORCE METHODS

The following physical force methods may be needed to clean some contaminants from the F73 cells. See Fig. 26. DO NOT use physical force methods on the filter screens.

1. High Pressure Air or Water. Either of these methods should prove to be adequate. However, care should be taken to avoid damage to the electronic cells.

**NOTE:** Using any caustic detergent with high pressure is dangerous.

If a detergent is required with the high pressure water, an alkaline detergent should be used if allowed by the high pressure equipment manufacturer. DO NOT use an acid detergent except when allowed by the equipment manufacturer.

2. Steam. Extreme care must be exercised when steam cleaning to avoid warping or bending the collector plates of the electronic cells or any other damage to the cells. Remember that the cells will be hot after steam cleaning and that care must be taken to avoid burns.

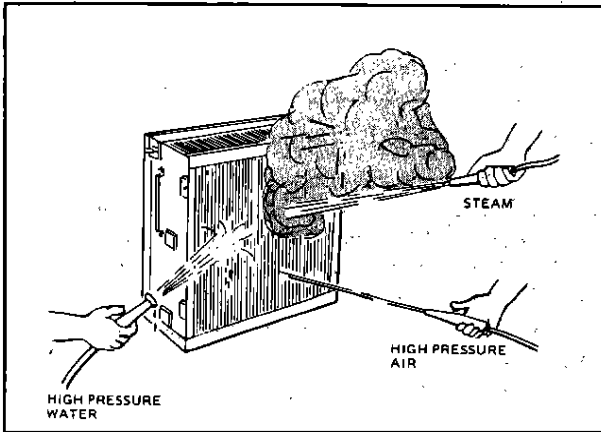

**FIG. 26 - IT MAY BE NECESSARY TO USE PHYSICAL FORCE METHODS TO REMOVE COLLECTED CONTAMINANTS.**

**CONTAMINANTS AND CLEANING PROCEDURES**

The following is a selective listing of contaminants captured by electronic air cleaners. This listing gives the appropriate cleaning procedure for various types of contaminants found on electronic air cleaner collector plates and prefilters.

| CONTAMINANT   | CLEANING PROCEDURE*   |
|---|---|
| Animal Hair   | Alkaline Solution   |
| Cabosil   | Alkaline Solution<br>High Pressure Air                      |
| Carbon (carbon black, soot, lamp black, graphite, charcoal dust, etc.)      | Alkaline Solution<br>High Pressure Air<br>High Press. Water |
| Cooking Oils<br>Veg. (soybean, peanut, etc.)<br>Animal (lard, butter, etc.) | Alkaline Solution<br>Steam                                  |
| Cotton Fibers   | Alkaline Solution   |
| Dust (silicon dioxide, calcium carbonate, and mineral type compounds)       | Alkaline Solution   |
| Flour Dust  | Alkaline Solution   |
| Linseed Oil   | Alkaline Solution   |
| Lubricants  | Alkaline Solution<br>High Press. Water                      |
| Metal Oxides  | Acid Solution   |
| Metals  | Acid Solution   |
| Mineral Oil (petroleum base, diesters, and silicone)                        | Alkaline Solution<br>High Press. Water                      |
| Paper Products  | Alkaline Solution   |
| Paint<br>Oil Base<br>Water Base   | Alkaline Solution<br>Alkaline Solution                      |
| Pine Tar Resins   | Alkaline Solution<br>Steam                                  |
| Polyethylene  | Alkaline Solution   |
| Polyphenyleneoxide  | Alkaline Solution   |
| Polypropylene   | Alkaline Solution   |
| Rubber Molding Accelerators   | Alkaline Solution   |

(continued next column)

| CONTAMINANT               | CLEANING PROCEDURE*                    |
|---------------------------|--|
| Soaps                     | Alkaline Solution                      |
| Sodium Chloride           | Alkaline Solution                      |
| Sugar (includes molasses) | Alkaline Solution<br>Steam             |
| Talc                      | High Pressure Air<br>Alkaline Solution |
| Tobacco Tars and Smoke    | Alkaline Solution                      |
| Varnishes                 | Alkaline Solution                      |
| Waxes (all types)         | Alkaline Solution<br>Steam             |
| Welding Fumes             | Acid Solution                          |
| Wood Products             | Alkaline Solution                      |

\*Cleaning procedures are listed in order of preference.

**REPLACING THE CELLS**

Before replacing the electronic cells, be sure to visually check the electronic cell for bent or damaged collector plates or broken ionizing wires.

Bent or warped collector plates may be bent back into shape.

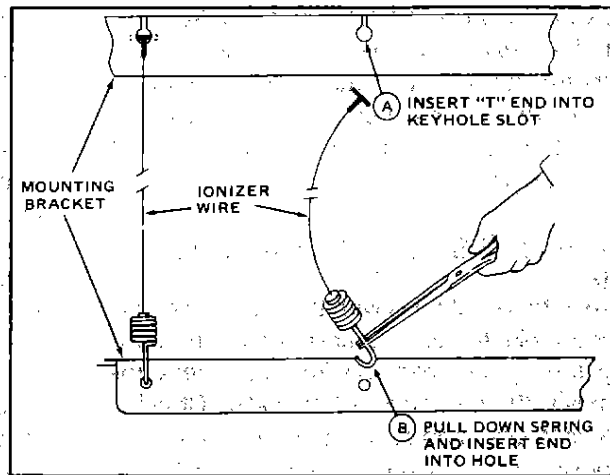

**FIG. 27 - REPLACING IONIZING WIRES**

Broken or damaged ionizing wires must be replaced for top efficiency. Remove all parts of the broken or damaged wire. Replacement wires come cut to length and ready for installation. Remember, when replacing the ionizing wires, to:

1. Use care to avoid damage to the spring connector or other parts of the cell during installation.
2. Hook the "T" end of the ionizing wire in the keyhole slot at one end of the cell.
3. Pull down the spring with a needlenose pliers and insert the hook into the hole.

Before replacing the cell, it might be a good idea to check it for a short circuit. This is done by using an ohmmeter to check the resistance between the frame of the cell and both the ionizer and collector contacts. In each case, the resistance should be infinite.

# TROUBLESHOOTING

## TROUBLESHOOTING PROCEDURE

The F73 Air Cleaner can be broken down into three basic systems.

1. Blower and motor
2. High voltage, power supply
3. Electronic cells

Most of the troubleshooting steps can be performed by observing the system light and by pushing the test button. If the system light is on, the test button creates an arcing noise when pushed, and the motor/blower creates a large discharge of air through the exhaust grilles; then the F73 is working properly.

Below is a list of symptoms of problems with the F73 Air Cleaner.

### Snapping or Arcing Noise

An occasional arcing noise is not a problem. It is caused when a large particle of dirt is pulled through the prefilter into the cell. Constant arcing is a problem. It is usually caused by collector plates that are bent or excessively dirty. Clean the cells and straighten any bent collector plates with a needlenose pliers.

### System Light is Out; Blower is Discharging Properly

Most likely the problem is with the electronic cells. Remove the electronic cells and turn the F73 on. If the system light comes on without the cells, the problem is with one or both of the cells. Check that the cells are clean and that there are not bent collector plates or broken ionizer wires. If the cells are shorted out, the system light will not come on. If the system light does not come on with the cells

removed from the F73, then the problem is with the high voltage power supply. The high voltage power supply will have to be replaced.

### System Light is Out; Blower is not Discharging Air

Most likely the problem is with the source voltage. Measure the voltage at the wiring compartment on the F73 Air Cleaner. Check the circuit breaker or fuse at the source voltage. If the proper voltage is measured at the F73 wiring compartment, call manufacturer.

### System Light is on and the Blower is Discharging Air, but Test Button Does not Produce an Arcing Sound

The problem is with the high voltage contacts from the power door to the contacts on the electronic cells. Check that the cells are installed properly with the airflow arrows pointing towards the blower. If the problem is not with the contact points then the problem is with the collector plates on the cells. Check for bent or extremely dirty collector plates.

### System Light is on; Blower is not Discharging Air

The most likely cause would be that the motor is overheating. This would cause the thermal protection to shut the motor off until the motor cools. The thermal protection will not affect the high voltage power supply or electronic cells. If the motor sheave has been adjusted to increase airflow, the current will have to be measured to insure that the current is not exceeding the rating for the air cleaner. This would cause the motor to overheat.

# PARTS LIST

| NO. | DESCRIPTION                  | F73A    | F73A    | F73B    |
|-----|------------------------------|---------|---------|---------|
|     |                              | 1 PHASE | 3 PHASE | 3 PHASE |
| 1   | On/Off Switch                | 10140   | 10140   | 10140   |
| 2   | Electronic Cells (2 per)     | 38010   | 38010   | 38010   |
| 3   | Motor Sheave                 | 30166   | 30166   | 30354   |
| 4   | Motor                        | 40039   | 40040   | 40041   |
| 5   | Blower                       | 37027   | 37027   | 37027   |
| 6   | Exhaust Grille (2 per)       | 30565   | 30565   | 30565   |
| 7   | Belt                         | 30234   | 30234   | 30234   |
| 8   | Power Door Assembly          | 05415   | 05414   | 05414   |
| 9   | Control Transformer          | N/A     | 10075   | 10075   |
| 10  | Motor Contactor              | 10078   | 10078   | 10078   |
| 11  | Blower Sheave                | 30167   | 30167   | 30557   |
| 12  | Pre/Postfilters (4 per)      | 41113   | 41113   | 41113   |
| 13  | System Light                 | 10097   | 10097   | 10097   |
| 14  | Power Supply Replacement Kit | 07083   | 07081   | 07081   |
| 15  | Male Connector (Power Door)  | 46199   | 46199   | 46199   |
| 16  | Female Connector             | 46198   | 46198   | 46198   |
| 17  | Cabinet Foot (4 per)         | 21411   | 21411   | 21411   |
| 18  | Hanger Bracket (4per)        | 21436   | 21436   | 21436   |
| 19  | Ionizing Wires               | 38005   | 38005   | 38005   |
| 20  | Source Capture Plenum        | 07107   | 07107   | 07107   |
| 21  | Impinger Assembly            | 07109   | 07109   | 07107   |
| 22  | Drain Pan                    | 07110   | 07110   | 07110   |

**For further information:**

**BERRIMAN ASSOCIATES**  
**1-800-480-3630**  
**www.berriman.com**